

LLISTAT DE PARTS DE CONJUNT

Part	Perfil	Material	Nº	Long.(mm)	Pes (kg)
PL4	PL 150*8	S275JR	12	150.0	17.0
PL5	PL 260*10	S275JR	6	350.0	42.9
PL6	PL 10*280	S275JR	30	280.0	184.6
PL19	PL 6*100	S275JR	6	100.0	2.8
PLA1	PL 280*12	S275JR	6	440.0	69.6
TB4	SHS140*5	S275JR	2	2596.4	106.5
TB5	SHS140*5	S275JR	2	2455.1	102.7
TB53	SHS150*5	S275JR	2	470.4	20.1
TB61	SHS150*5	S275JR	2	3640.0	165.7
TB62	SHS150*5	S275JR	2	2909.4	132.5
TB83	SHS150*6	S275JR	1	470.4	12.0
TB86	SHS140*4	S275JR	1	4433.8	72.3
TB89	SHS140*4	S275JR	2	3806.7	123.7
TB90	SHS140*4	S275JR	1	4070.2	67.3
TB91	SHS140*4	S275JR	1	4406.2	71.9
TB98	SHS140*4	S275JR	2	4315.3	141.3
TB105	SHS140*4	S275JR	2	2147.2	70.3
TB107	SHS140*4	S275JR	2	2147.2	70.3
TB109	SHS140*4	S275JR	1	3449.9	58.9
TB109	SHS140*4	S275JR	6	3450.0	353.6
TB110	SHS140*4	S275JR	4	2455.1	165.5
TB111	SHS140*4	S275JR	6	42.3	2.2
TB114	SHS140*4	S275JR	8	1714.5	234.3
TB116	SHS140*4	S275JR	1	3450.0	58.9
TB118	SHS140*4	S275JR	1	3450.0	57.8
TB119	SHS140*4	S275JR	4	2596.4	171.6
TB128	SHS140*4	S275JR	2	1714.5	56.4
TB129	SHS140*4	S275JR	4	1892.8	123.0
TB130	SHS140*4	S275JR	2	2024.6	66.9
TB132	SHS140*4	S275JR	1	3450.0	57.8
TB134	SHS140*4	S275JR	2	2215.3	71.8
TB135	SHS140*4	S275JR	2	2215.3	71.8
TB170	SHS150*10	S275JR	1	3640.0	160.0
TB171	SHS150*10	S275JR	1	2909.4	127.9
TB172	SHS140*6	S275JR	2	4315.3	208.9
TB173	SHS140*6	S275JR	2	3806.7	182.9
TB174	SHS140*6	S275JR	1	4070.2	99.5
TB175	SHS140*6	S275JR	1	4406.2	106.3
TB176	SHS140*6	S275JR	1	4433.8	107.0
Total					4016.4

Tipo de hilo	Nº de Colada	Control de qualitat
Data	Operari	Maquina

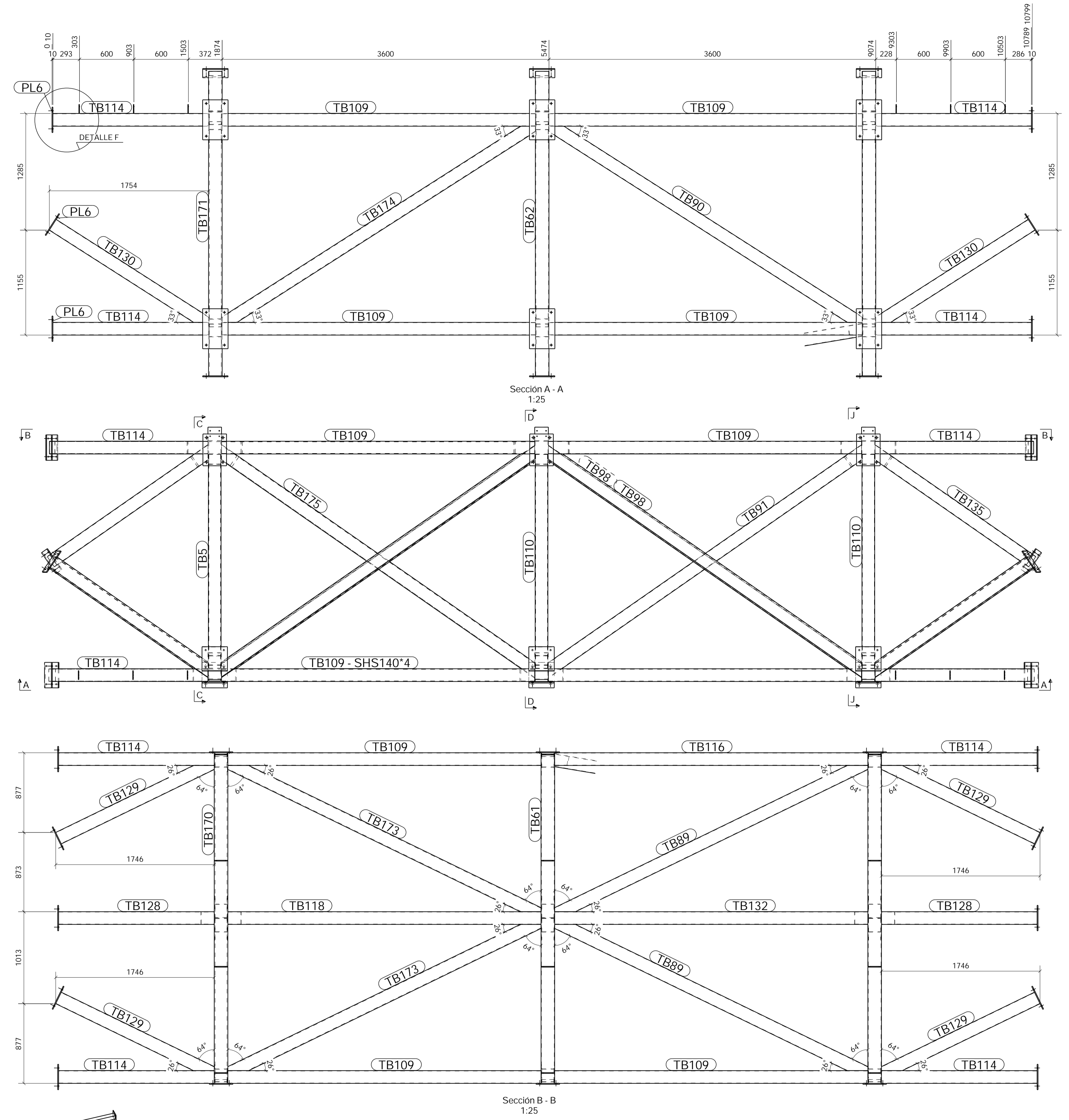
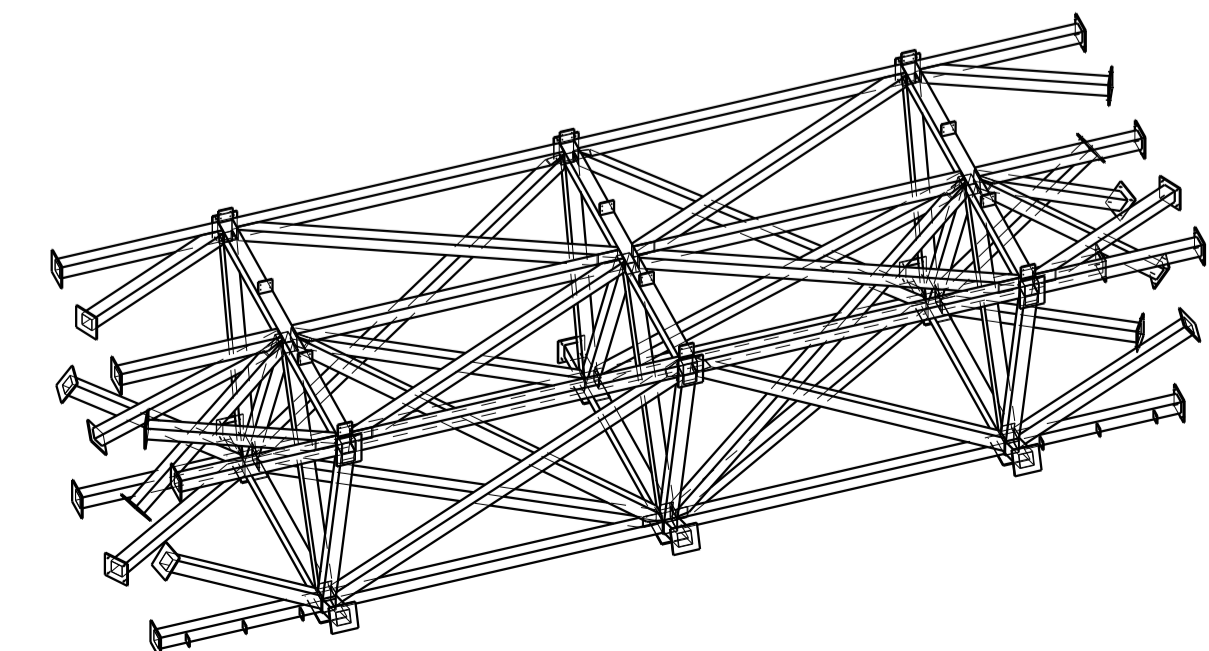
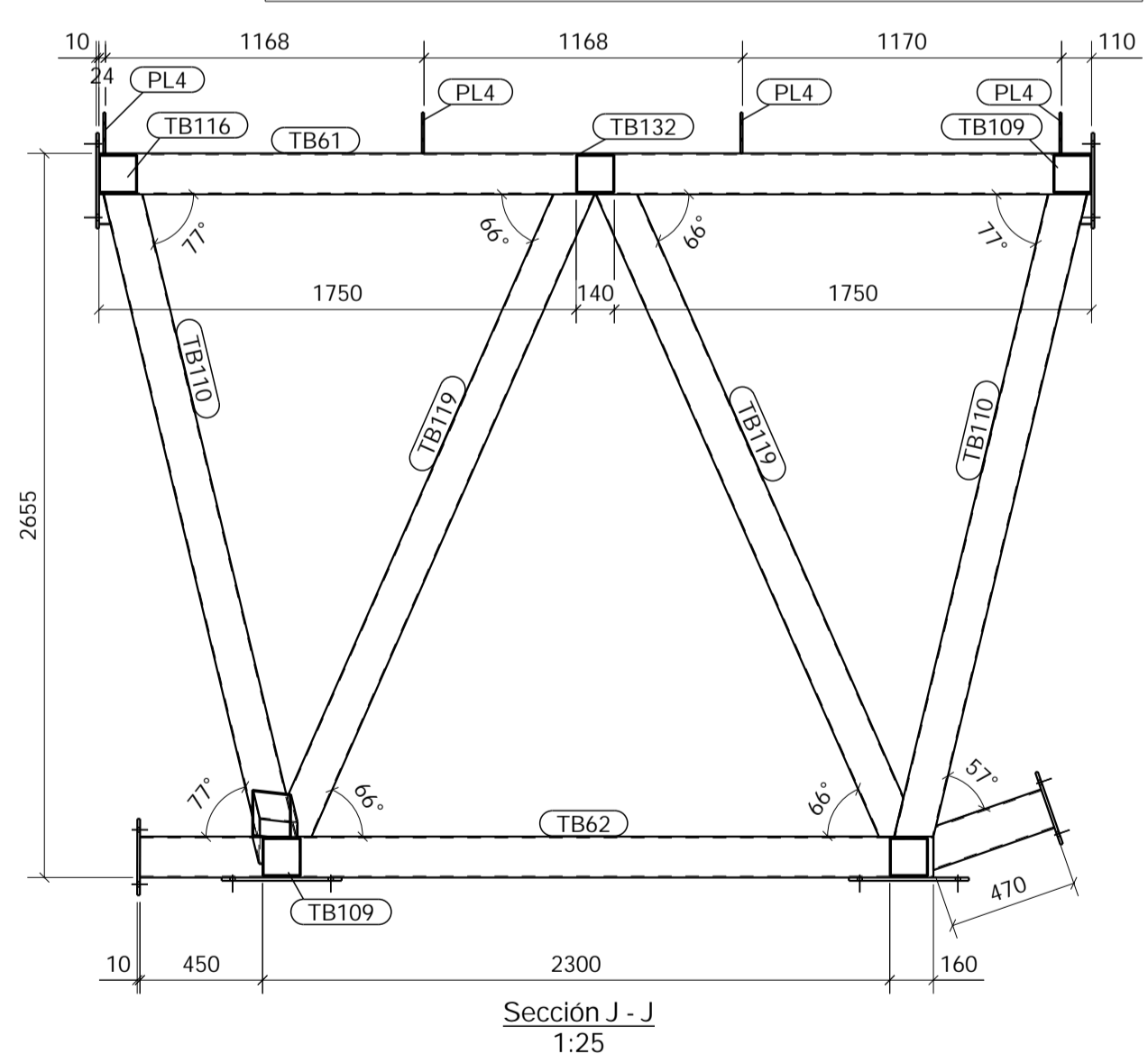

Nº REV.	REVISIÓ	DESCRIPCIÓ DE REVISIÓ	DATA REV.

CASANOVA SA
CONSTRUCCIONS METAL·LÚRIQUES

Tel: +34 972 238 750 Fax: +34 972 232 750

PROYECTO LES PLANES

CONSTRUCTOR ARCADÍ PLA

ESCALA 1:15

PROYECTO EUROPEA

NÚMERO DE PROYECTO: 219/2017

NÚMERO DE DIBUIX: A [ENC.2]

BIGA W

TEKLA Structures

Sección View_03 (Vista básica) - View_03 (Vista básica) 1:75