

CONNECTION A

ISOMETRIC VIEW
1:5

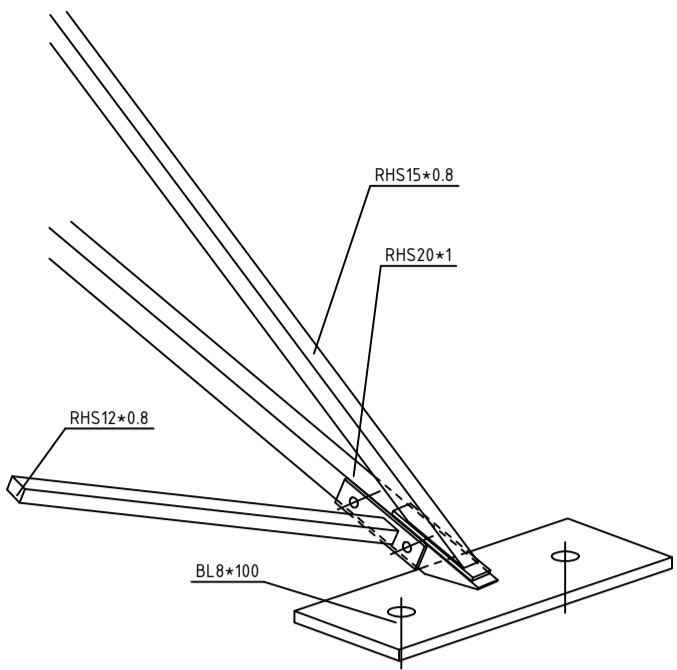

TOP VIEW
1:5

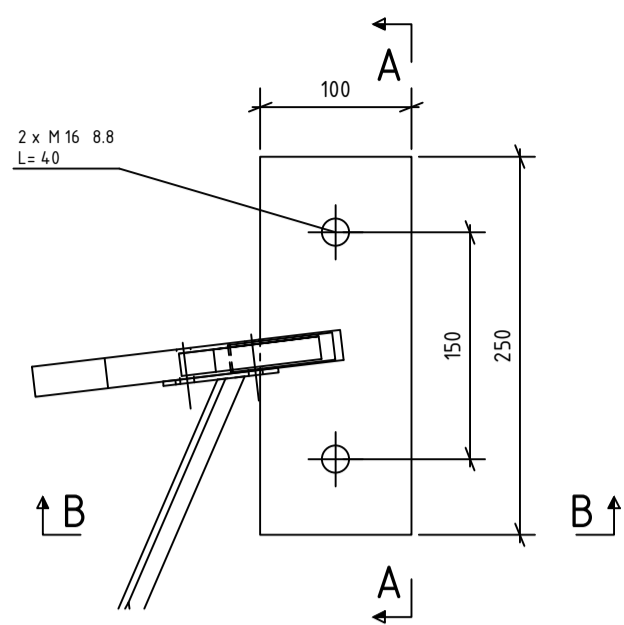

A - A
1:5

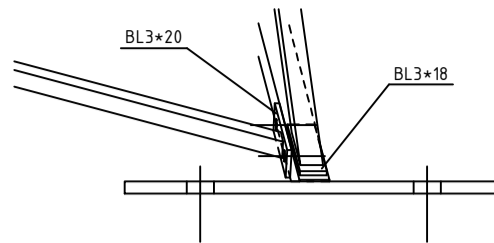

B - B
1:5

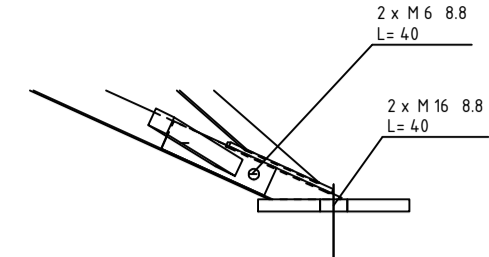

CONNECTION B

ISOMETRIC VIEW
1:5

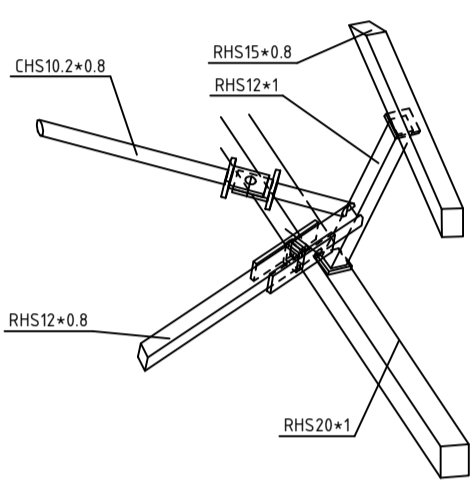

TOP VIEW
1:5

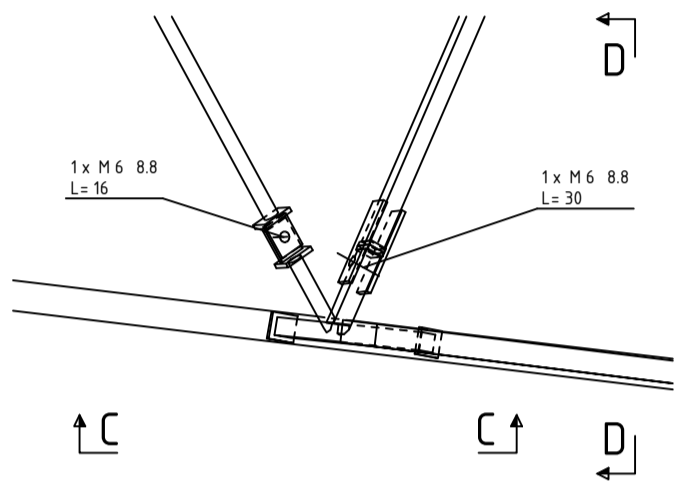

C - C
1:5

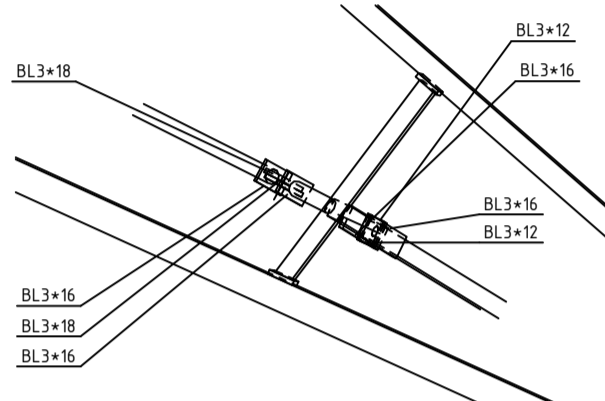

D - D
1:5

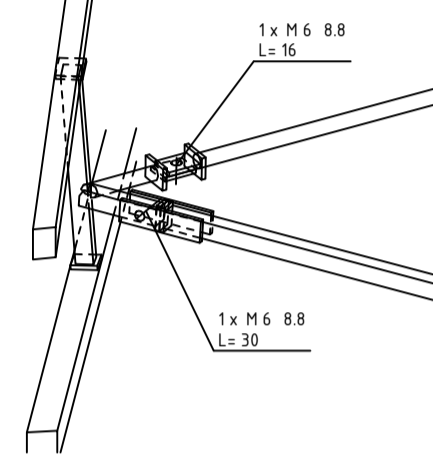

CONNECTION C

ISOMETRIC VIEW
1:5

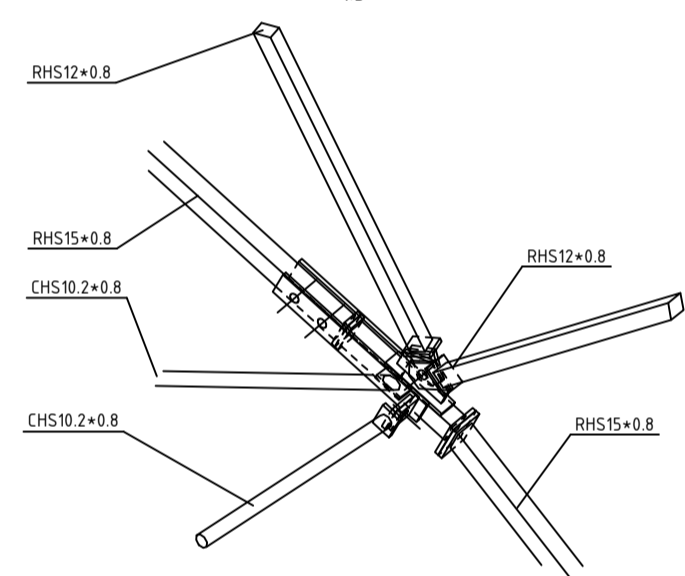

TOP VIEW
1:5

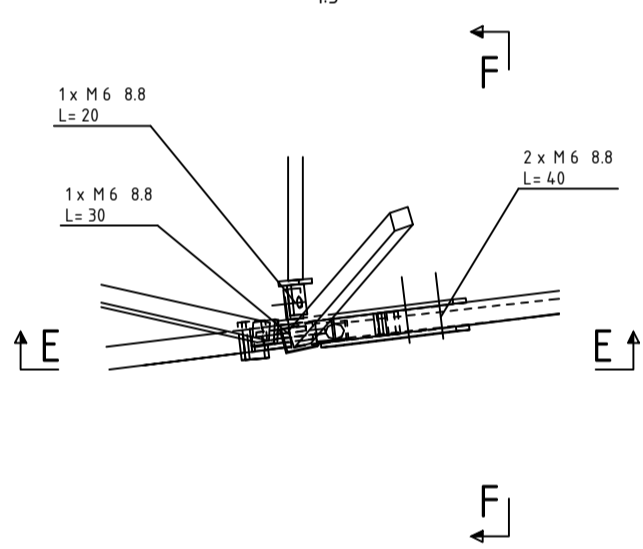

E - E
1:5

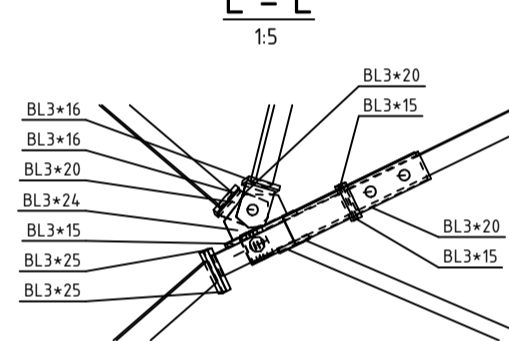

F - F
1:5

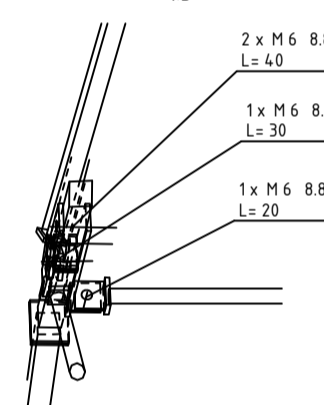

CONNECTION D

ISOMETRIC VIEW
1:5

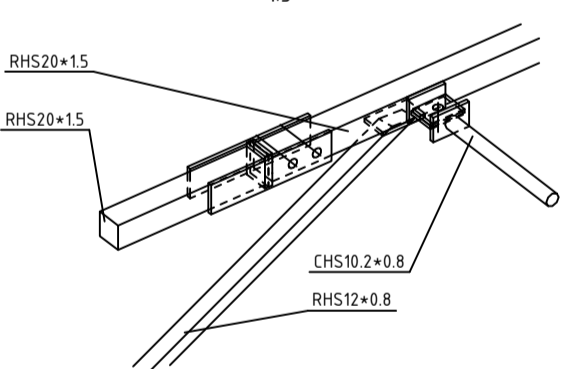

TOP VIEW
1:5

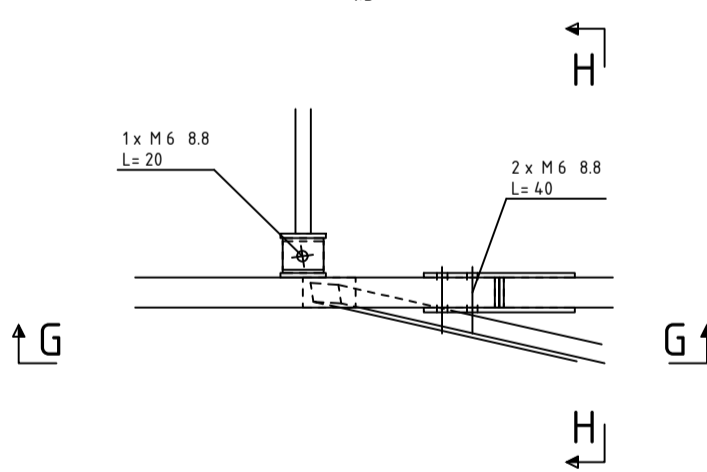

G - G
1:5

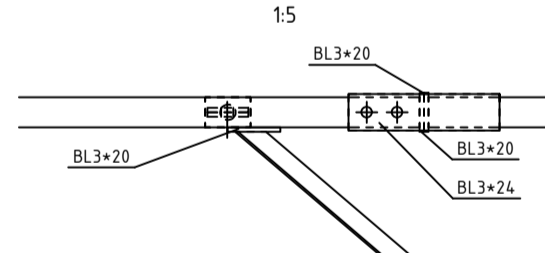

H - H
1:5

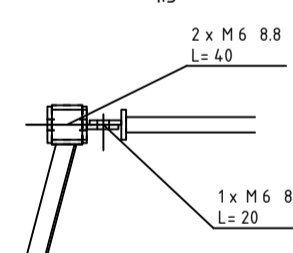

CONNECTION E

ISOMETRIC VIEW
1:5

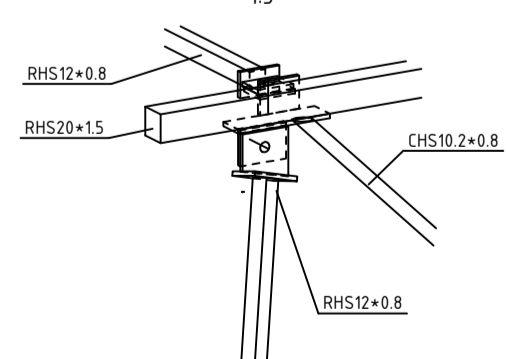

TOP VIEW
1:5

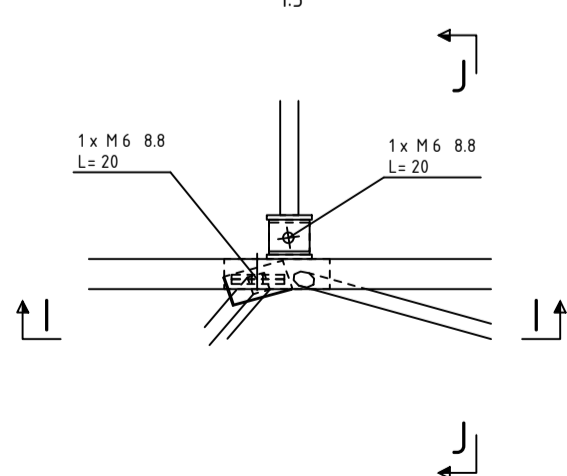

I - I
1:5

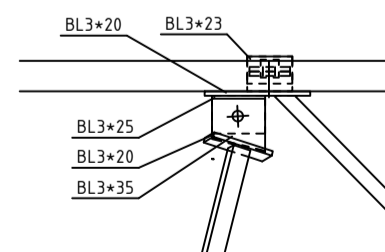

J - J
1:5

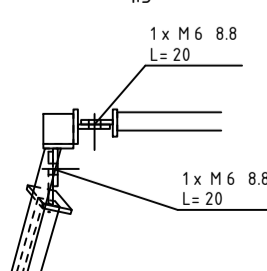

DESIGNED BY TEAM COBBLESTONE SILESIAN UNIVERSITY OF TECHNOLOGY ul. Akademicka 5, 44-100 Gliwice	
PROJECT BRICO2020 THE NORDIC STEEL BRIDGE COMPETITION TALLINN ESTONIA	
INVESTOR	
DRAWN BY	
STUDENT CLUB FUTURE STRUCTURAL ANALYSES ASSOCIATED WITH DEPARTMENT OF MECHANICS AND BRIDGES INDUSTRY - PHASE Building industry - Preliminary design	
PROJECT NUMBER 2020/BRC	DRAWING NUMBER BRC-1-004
SCALE 1:5	DRAWING TITLE CONNECTIONS DETAILS 1
DATE 06.02.2020	