

BILL OF MATERIAL					
MARK	QTY	DESCRIPTION	LENGTH	WEIGHT	REMARKS
19M1	1	HEEL ASSEMBLY			
19M1	1	PIPE2-1/2SCH80	14-6 3/16	104	A53-GR.B
m61	1	PIPE6SCH80	1-4 3/16	36	A53-GR.B
m62	1	PIPE6SCH80	1-5	38	A53-GR.B
p63	1	PL1"x9 3/8"	0-9 1/2	21	A572-50
p64	1	PL1/2"x3 3/8"	1-4 1/8	4	A572-50
p65	1	PL1/2"x2 15/16"	1-4 1/16	3	A572-50
p66	1	PL1"x14 1/16"	1-6 13/16	57	A572-50
p73	2	PD12"x3 1/8"	0-0 7/8	43	A572-50
	8	3/4" A325N BOLT		0-3	Site
TOTAL WEIGHT THIS DRAWING				305	

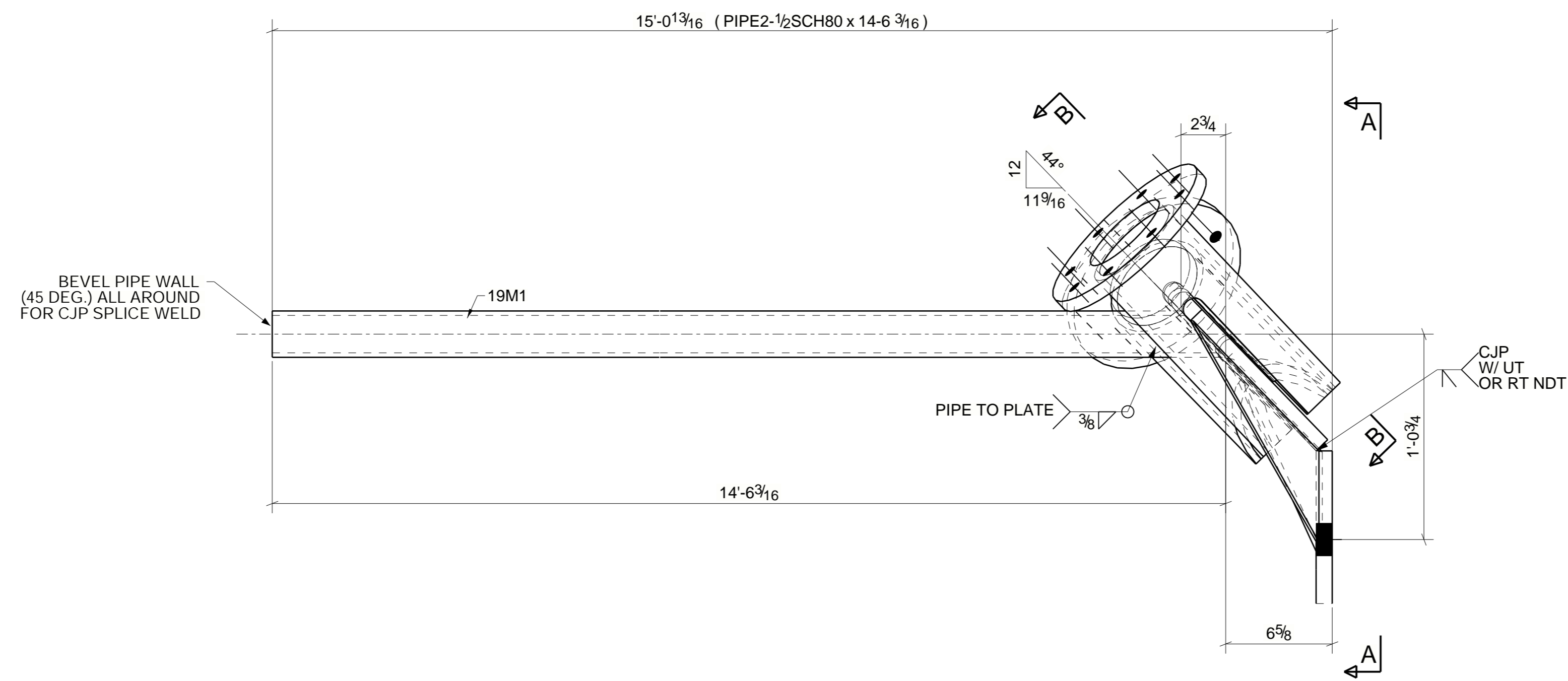

NOTE:
PLEASE USE 21M1 TO
ASSEMBLY THE HEEL

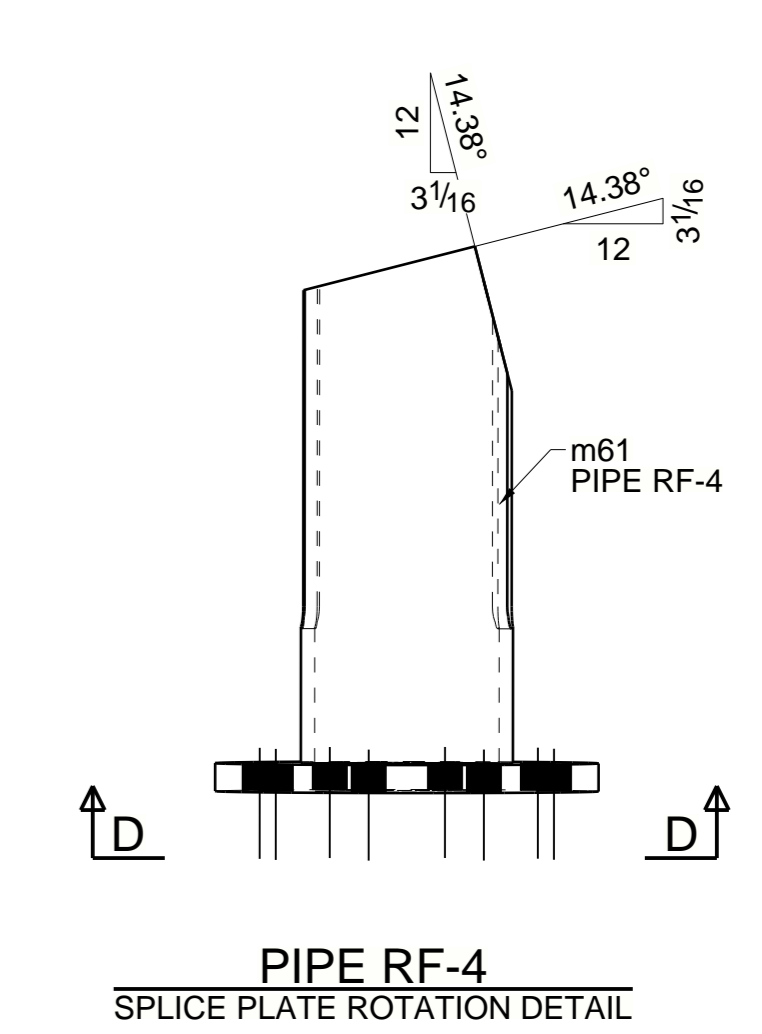
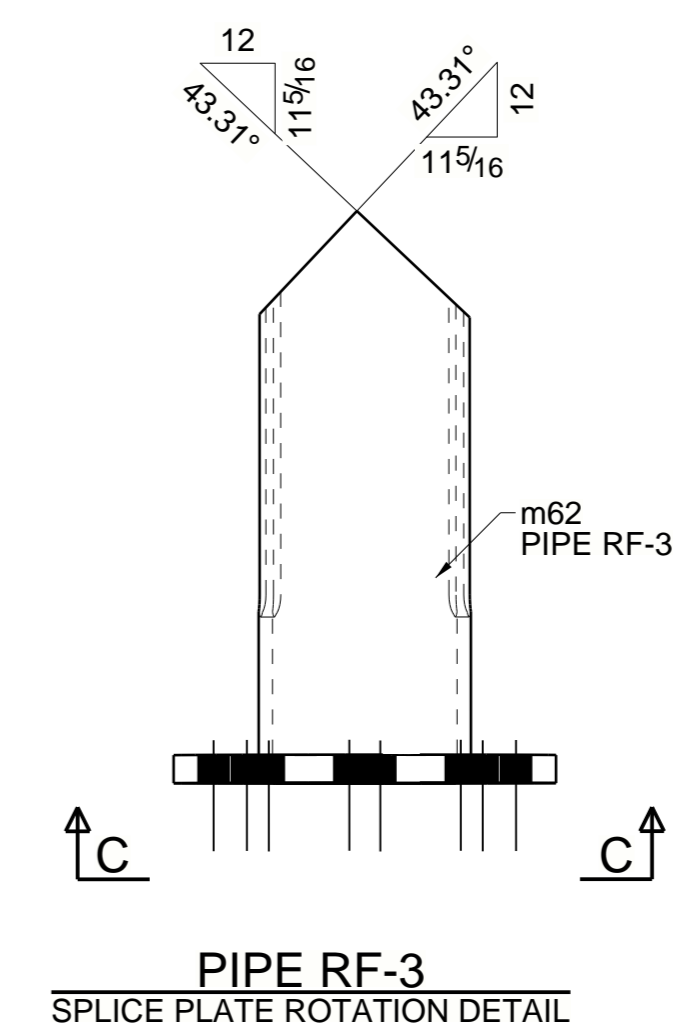
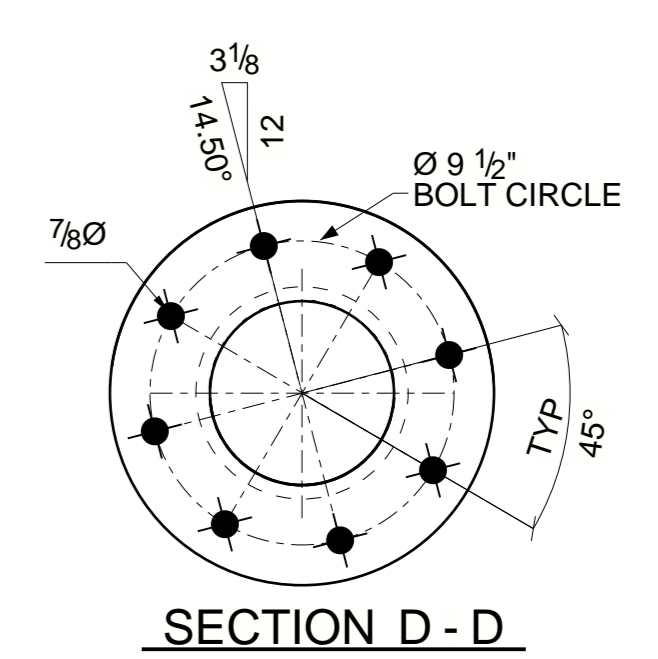
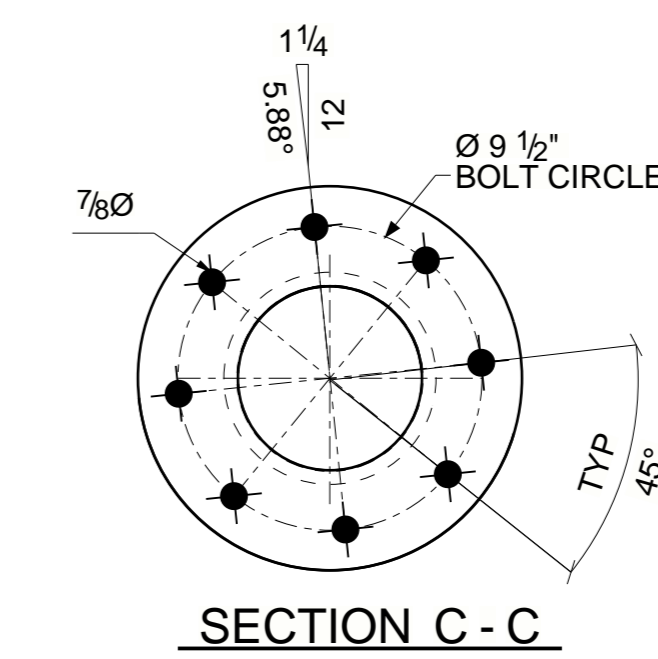
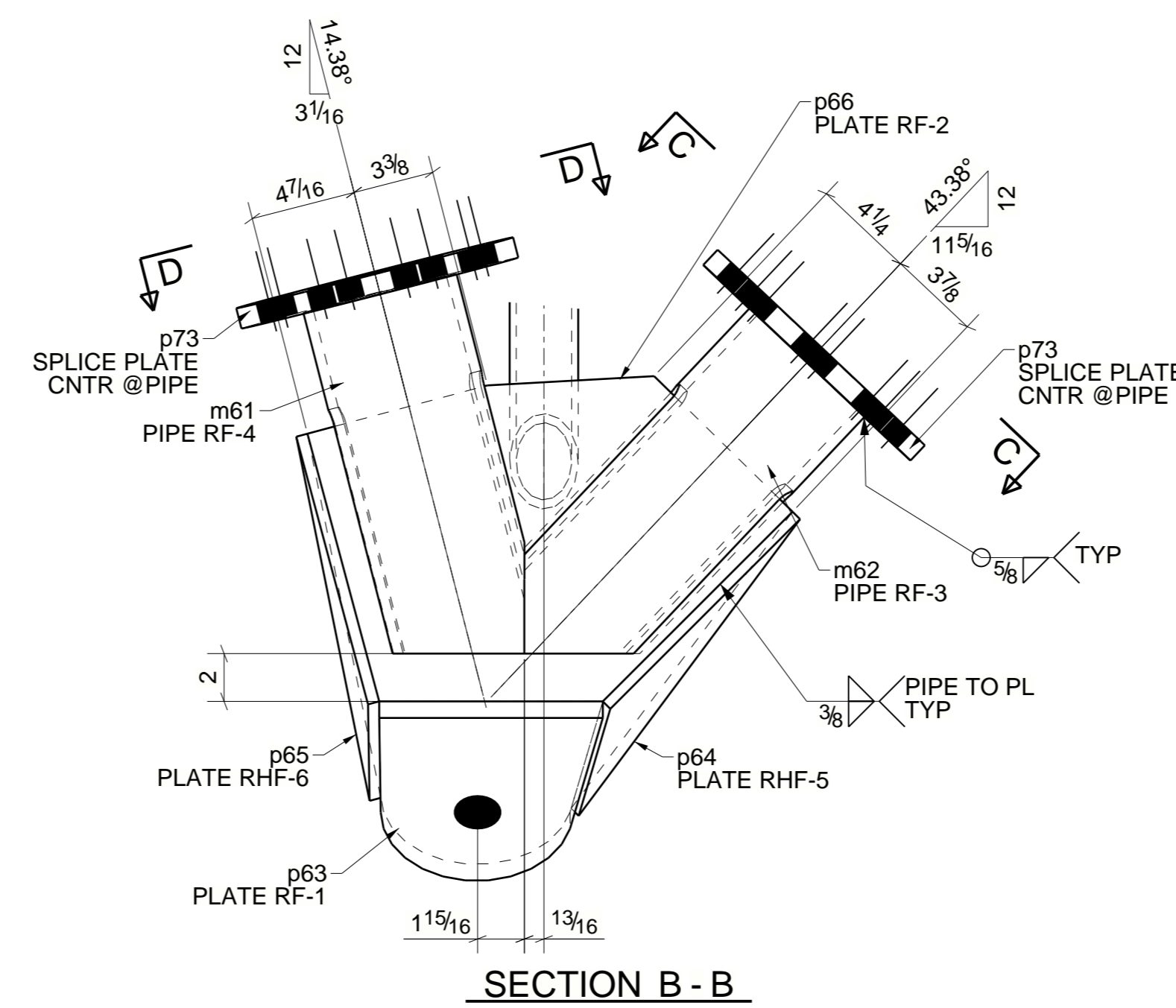
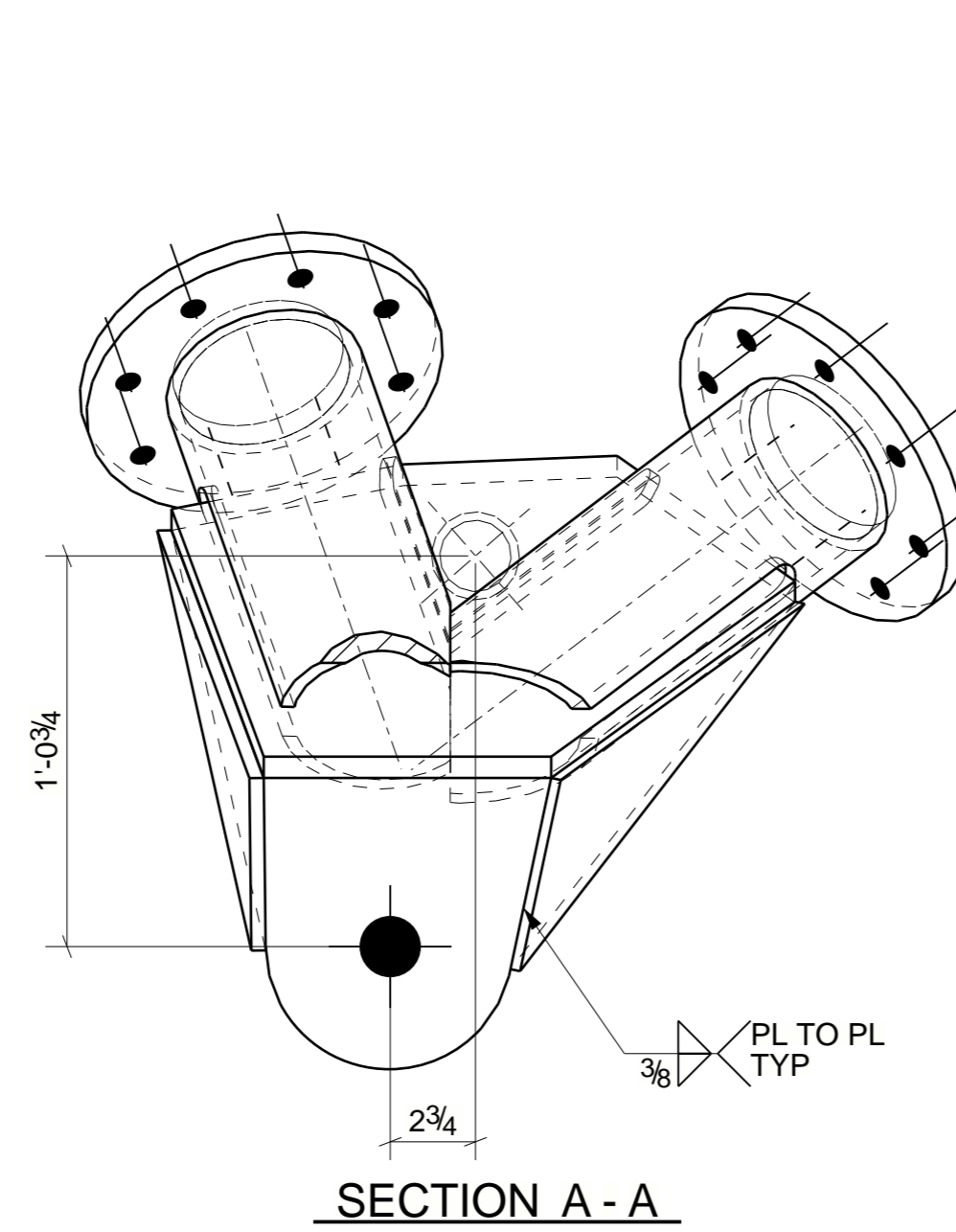

ONE - HEEL ASSEMBLY - 19M1