

NOTE: VIEW ARROW MUST BE SHOWN ON THE SLAB

Note: For joint profiles see drawing:
03-GRA-0058-FPM-RC-XX-DR-X-0604
03-GRA-0058-FPM-RC-XX-DR-X-0605

NOTE: USE BALCONY BRACKETS
MARKED WITH RED PAINT

BRICK ITEMS: PER UNIT
Refer to drawing 03-GRA-0058-FPM-RC-XX-DR-X-1400

No.	Item	Kemsley Yellow
1	Cut Header	56x50
1	Cut Header	52x65
1	Cut Header	52x60
1	Cut Header	52x45
2	Cut Header	56x65

Mortar specification:
Ultrascape Regency Limepoint Sandstone

All joints in brickwork 10mm nominal (unless noted otherwise)
Raked pointing required (unless noted otherwise)

NOTES:

Type	FLOOR SLAB	
Length.	3697	+5/ -5
Height.	3680	+5/ -5
Thick.	200	+3 / -3
X to Y (Diag)		+5 / -5
Weight. (T)	3.876	
Volume. (m³)	1.544	
Concrete.	Grade C45/55	
Exposure Class	XC4+XF3	
Fire Rating	90 mins	
Mix.	GRA-01	
Lifting Strength.	15N/mm²	
Finishes.	NF Steel Trowel, FF Type B	
RC Drg. Ref.	03-GRA-0058-FS-0009-RC	
Cover.	30mm Nominal, (25mm Minimum)	
Casting Bed.	Flat	
Lifting.	See Diagram	
Mark.	FS-0009	
Stacking.	Flat	

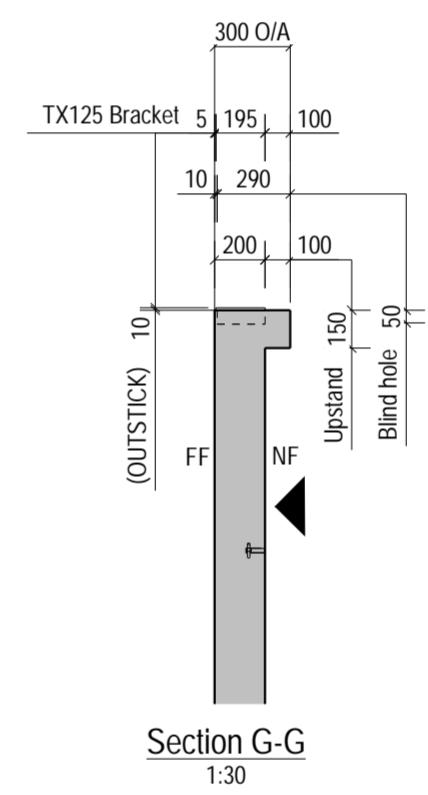
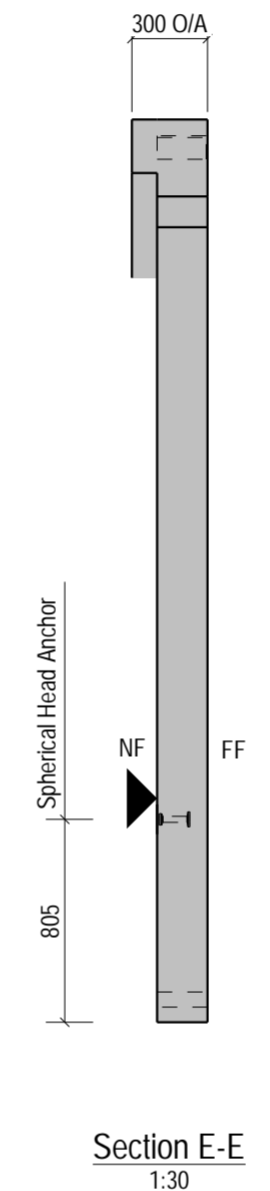
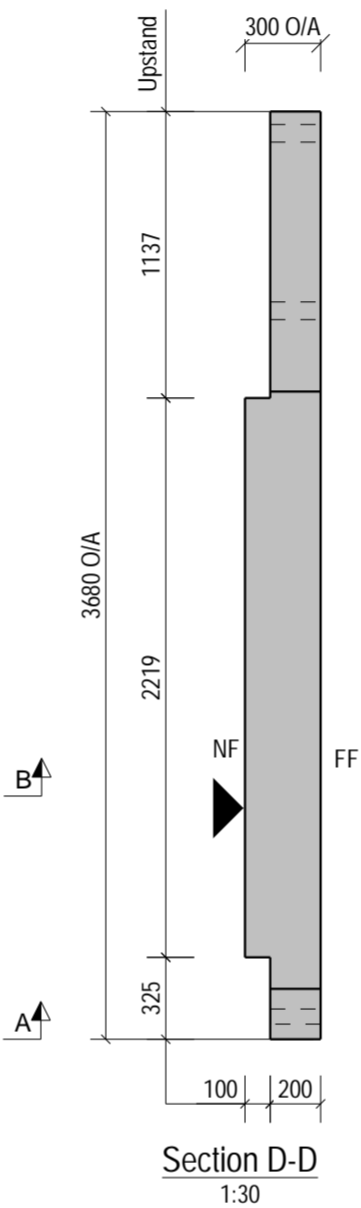
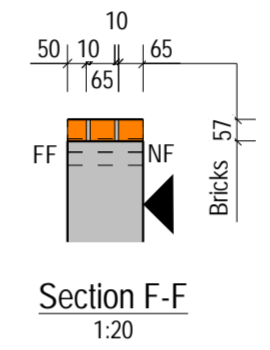

ENCAST ITEMS: PER UNIT

No.	Item	Ref.
7	TX125 Bracket	Brooksby TX125 10mm PL
4	Well Void	WV60 L=200
3	Spherical Head Anchor	SAP0075120
2	Well Void	WV7035 L=200
1	M16 Crosspin Socket	SSSCP1675

Level	Quantity
1	1
2	1
3	1
4	1
Total	4

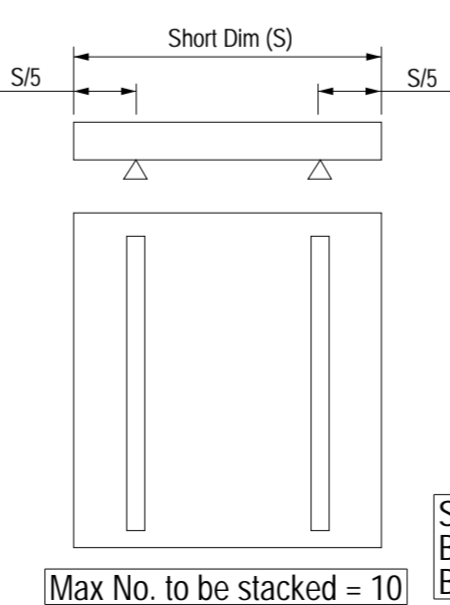
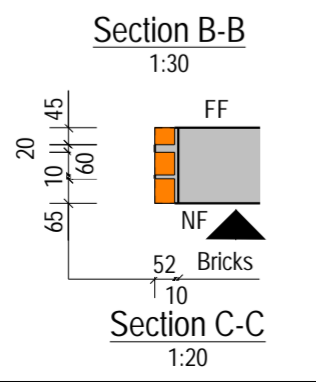
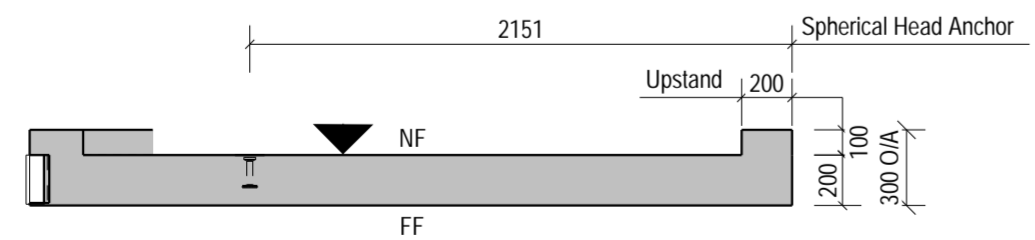
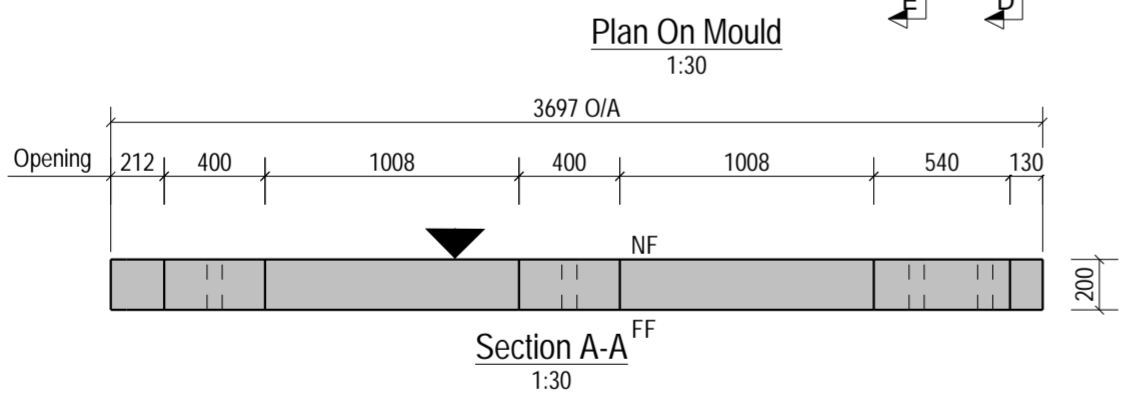

Slabs to be stacked in the same orientation.
Bearers to be 150mm longer than unit.
Bearers to align in stack.

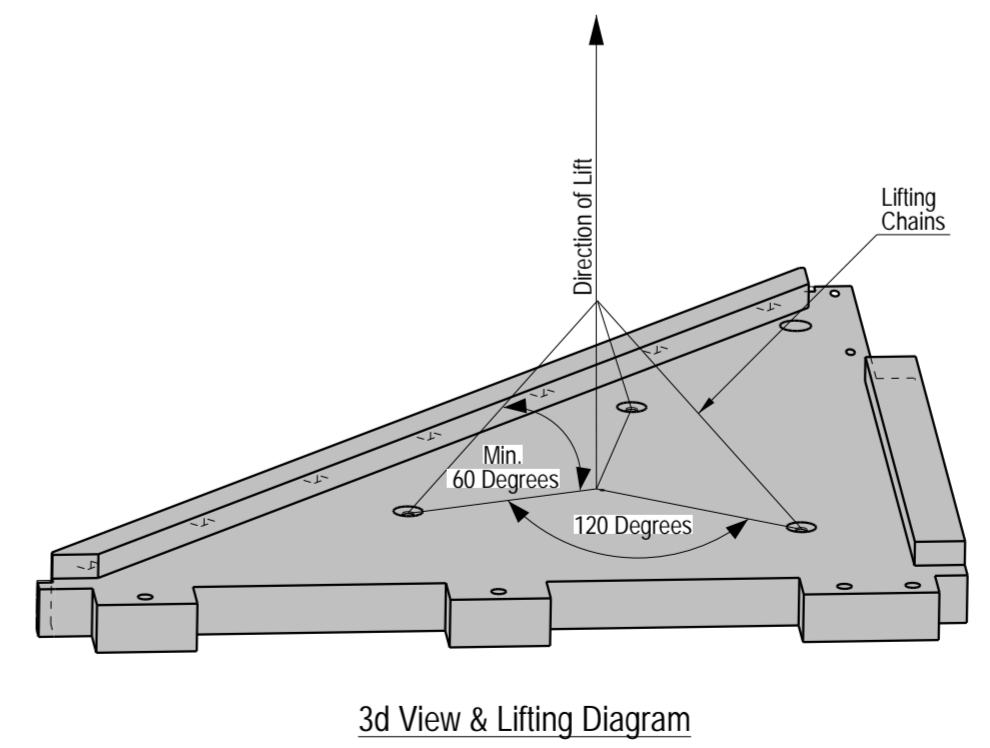

▲ = Viewing arrow

Rev	Date	Revision Detail	By	Chk	App
C03	20-04-23	Well voids change	APO	MAN	MMI
C02	11-04-23	Issued For Manufacture	APO	MAN	MMI
C01	21-03-23	Issued For Manufacture	APO	MAN	MMI

FP McCann
Byley,
King's Lane,
Byley,
Middlewich, Cheshire
CW10 9NB.
Tel: +44 (0)1606 843500
www.fpmccann.co.uk

FP McCann
Grantham,
Alma Park Road,
Grantham,
Lincolnshire,
NG31 5SE.
Tel: +44 (0)1476 562277
www.fpmccann.co.uk

Client: **Hollybrook Homes**

Project: **Roneo Corner, Hornchurch**

Title: **GA of FLOOR SLAB FS-0009**

Scale: As Shown Status: Issued for Manufacture - A

Drawn: APO Checked: MAN Approved: MMI
Drawing No: 03-GRA-0058-FS-0009-GA Rev: C03

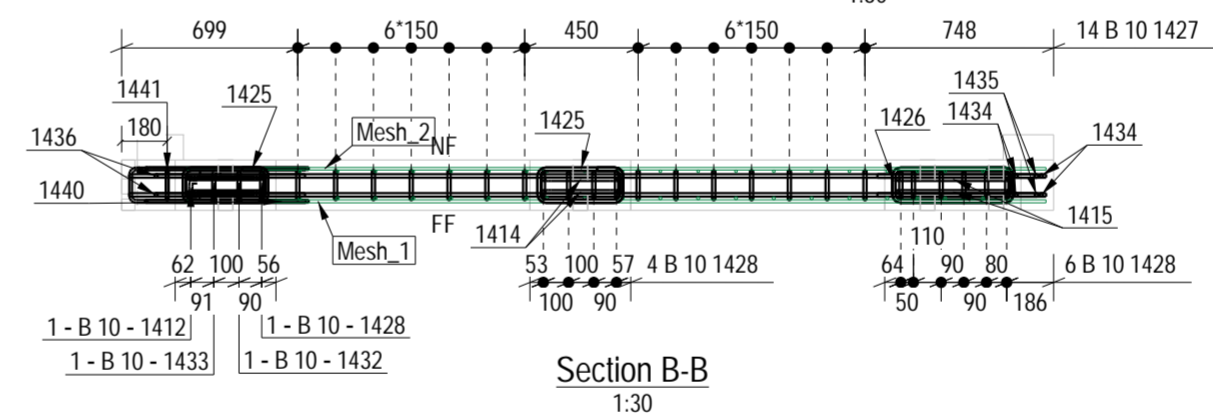
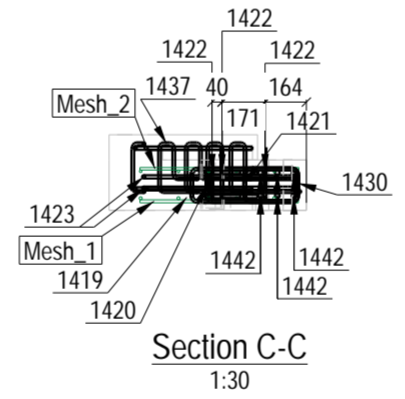
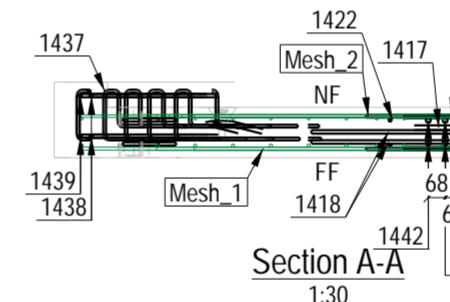
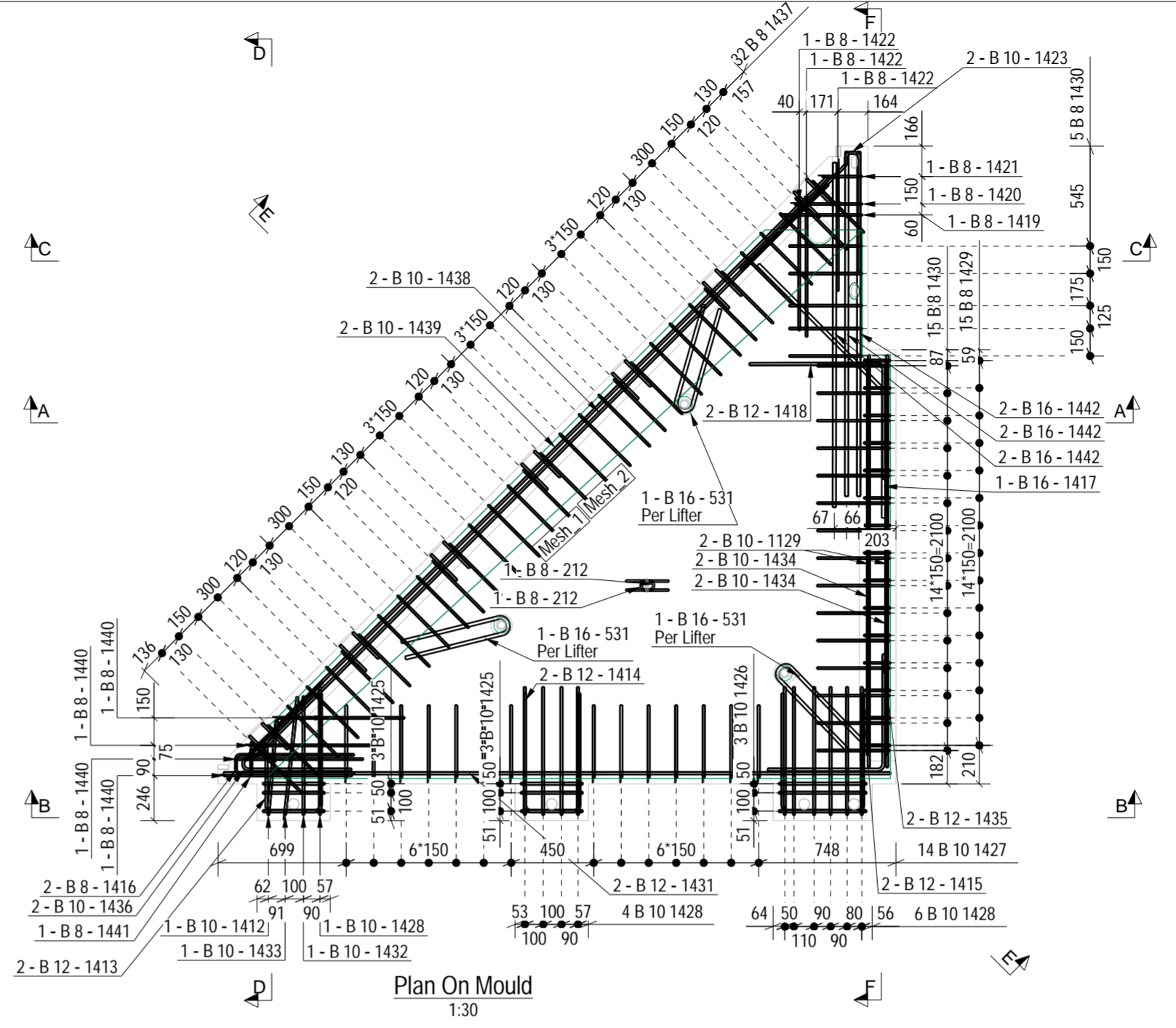
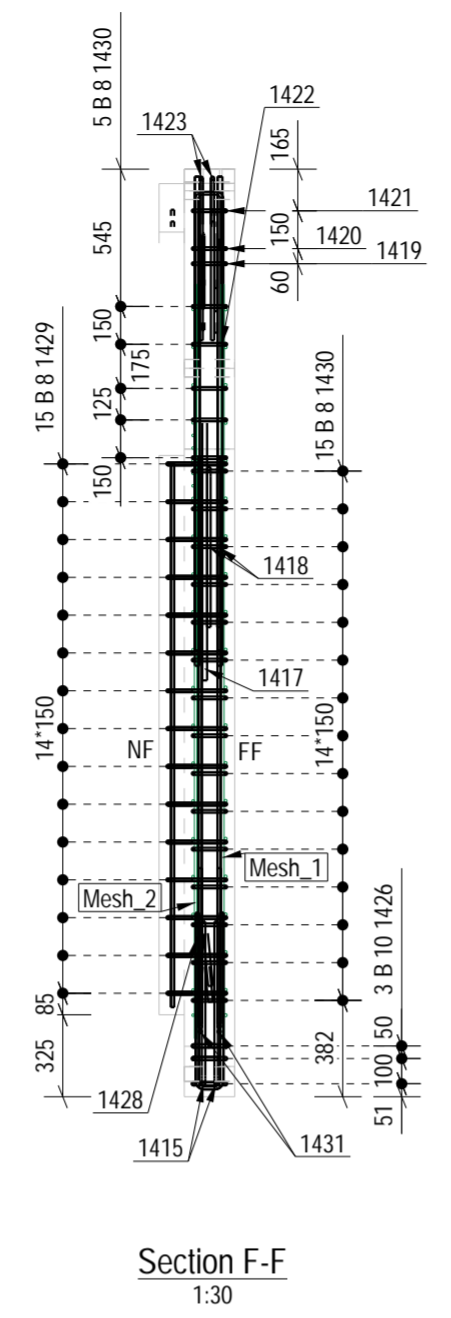
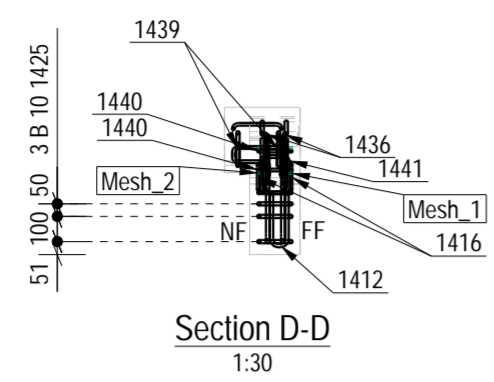
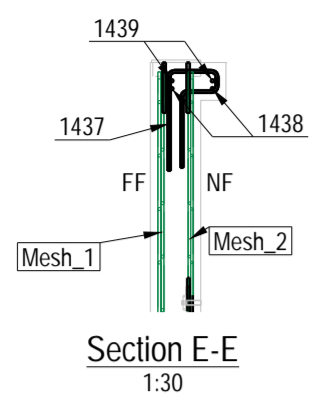

Bar Mark	Type & Size	No. of members	No. per member	Total No.	Shape Code	Lgth of each bar #	a *	b *	c *	d *	e *	r	kg/bar	kg/all
212	B 8	4	2	8	13	325	155	60	155				0.1	1.1
1129	B 10	4	2	8	00	2150	2155						1.3	10.6
1413	B 12	4	2	8	36	1650	365	390	310	650	265		1.5	11.8
1414	B 12	4	2	8	21	1550	650	310	650				1.4	11.1
1415	B 12	4	2	8	21	1700	650	450	650				1.5	12.1
1416	B 8	4	2	8	21	1375	650	110	650				0.5	4.3
1417	B 16	4	1	4	15	1650	700	505	970				2.6	10.5
1418	B 12	4	2	8	11	1350	635	735				24	1.2	9.6
1419	B 8	4	1	4	41	1150	115	430	140	430	115		0.5	1.8
1420	B 8	4	1	4	41	1050	115	370	140	370	115		0.4	1.6
1421	B 8	4	1	4	41	750	115	220	140	220	115		0.3	1.2
1422	B 8	4	3	12	21	1475	700	110	700				0.6	7.0
1425	B 10	4	6	24	51	1050	340	140	100	100			0.6	15.4
1426	B 10	4	3	12	51	1325	480	140	100	100			0.8	9.8
1427	B 10	4	14	56	21	875	400	120	400				0.5	30.1
1428	B 10	4	11	44	21	1450	700	110	700				0.9	39.6
1430	B 8	4	20	80	21	900	400	140	400				0.4	28.4
1431	B 12	4	2	8	00	3625	3635						3.2	25.8
1432	B 10	4	1	4	21	1350	650	110	650				0.8	3.4
1433	B 10	4	1	4	21	1375	650	115	650				0.8	3.4
1434	B 10	4	4	16	00	2225	2245						1.4	22.2
1435	B 12	4	2	8	11	1250	635	635				24	1.1	8.9
1438	B 10	4	2	8	00	4400	4415						2.7	21.8
1439	B 10	4	2	8	00	4475	4480						2.8	22.1
1440	B 8	4	4	16	21	1500	700	140	700				0.6	9.5
1442	B 16	4	6	24	00	1875	1880						3.0	71.3
1412	B 10	4	1	4	99-1412	1300							0.8	3.2
1423	B 10	4	2	8	99-1423	1575							1.0	7.7
1429	B 8	4	15	60	99-1429	875							0.3	20.6
1436	B 10	4	2	8	99-1436	1250							0.8	6.1
1437	B 8	4	32	128	99-1437	1075							0.4	54.0
1441	B 8	4	1	4	99-1441	650							0.2	1.0
531	B 16	4	3	12	13	1225	600	110	600				2.0	23.4
Mesh_1		4	1	4									52.04	208.18
Mesh_2		4	1	4									35.36	141.43

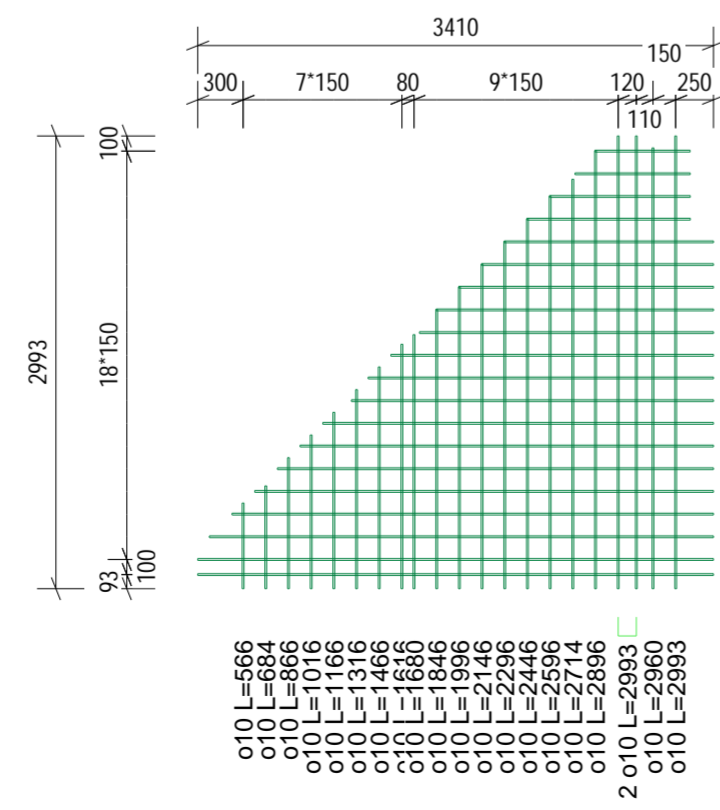
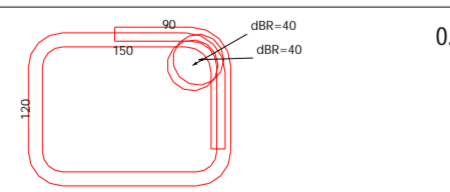
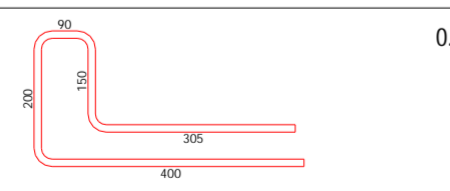
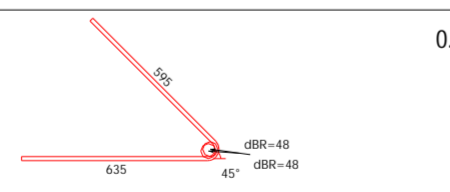
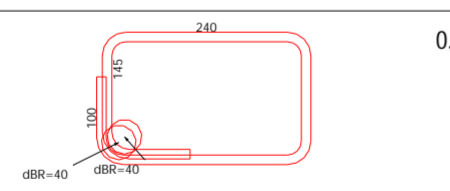
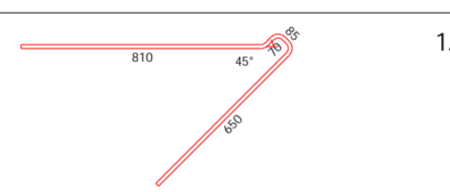
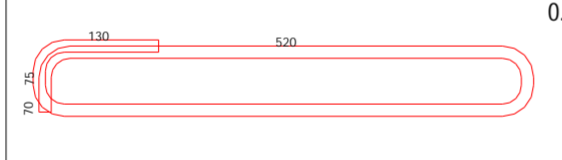

- o10 L=628
- o10 L=761
- o10 L=929
- o10 L=1080
- o10 L=1383
- o10 L=1533
- o10 L=1683
- o10 L=1833
- o10 L=1951
- o10 L=2133
- o10 L=2283
- o10 L=2401
- o10 L=2583
- o10 L=2733
- o10 L=2883
- o10 L=3033
- o10 L=3183
- o10 L=3333
- 2 o10 L=3410

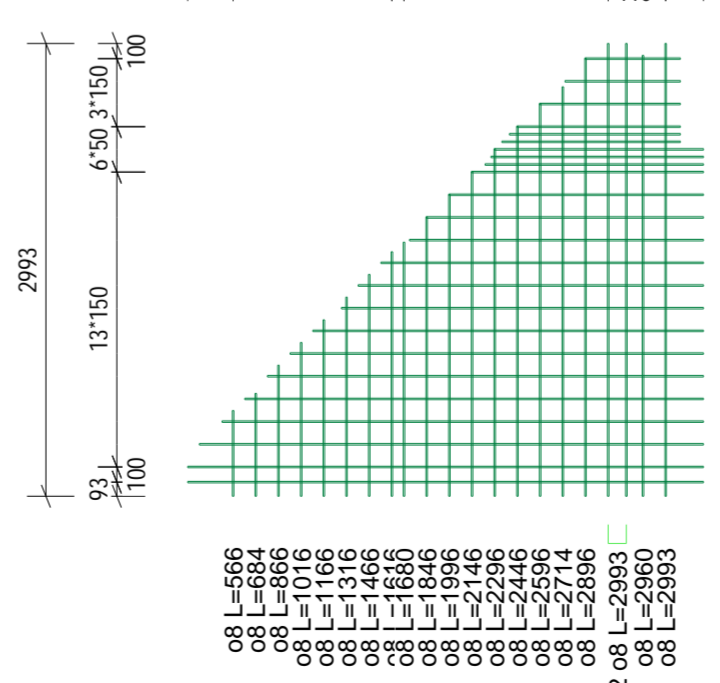

- o8 L=630
- o8 L=763
- o8 L=930
- o8 L=1080
- o8 L=1130
- o8 L=1180
- o8 L=1383
- o8 L=1405
- o8 L=1451
- o8 L=1533
- o8 L=1683
- o8 L=1833
- o8 L=1951
- o8 L=2133
- o8 L=2283
- o8 L=2401
- o8 L=2583
- o8 L=2733
- o8 L=2883
- o8 L=3033
- o8 L=3183
- o8 L=3333
- 2 o8 L=3410

NOTES:

Type.	FLOOR SLAB
Mark.	FS-0009
GA Drg. Ref.	03-GRA-0058-FS-0009-GA
Quantity.	4
Cover	30mm

- Reinforcement (500B or C) to BS4449.
- Scheduling, dimensioning, bending and cutting to BS8666.
- Cage to be tack welded and/or tied with 17 gauge annealed tying wire.

Rev	Date	Revision Detail	By	Chk	App
C03	20-04-23	Well voids change			APO/MAN/MMI
C02	11-04-23	Issued For Manufacture			APO/MAN/MMI
C01	21-03-23	Issued For Manufacture			APO/MAN/MMI

FP McCann
Byley, King's Lane, Byley, Middlewich, Cheshire CW15 9NB.
Tel: +44 (0)1606 843500 www.fpmccann.co.uk

FP McCann
Grantham, Alma Park Road, Grantham, Lincolnshire, NG31 5SE.
Tel: +44 (0)1476 562277 www.fpmccann.co.uk

Client: Hollybrook Homes

Project: Roneo Corner, Hornchurch

Title: RC of FLOOR SLAB FS-0009

Scale: As Shown Status: Issued for Manufacture - A
Date: 21-03-23

Drawn: APO Checked: MAN Approved: MMI
Drawing No: 03-GRA-0058-FS-0009-RC Rev: C03