

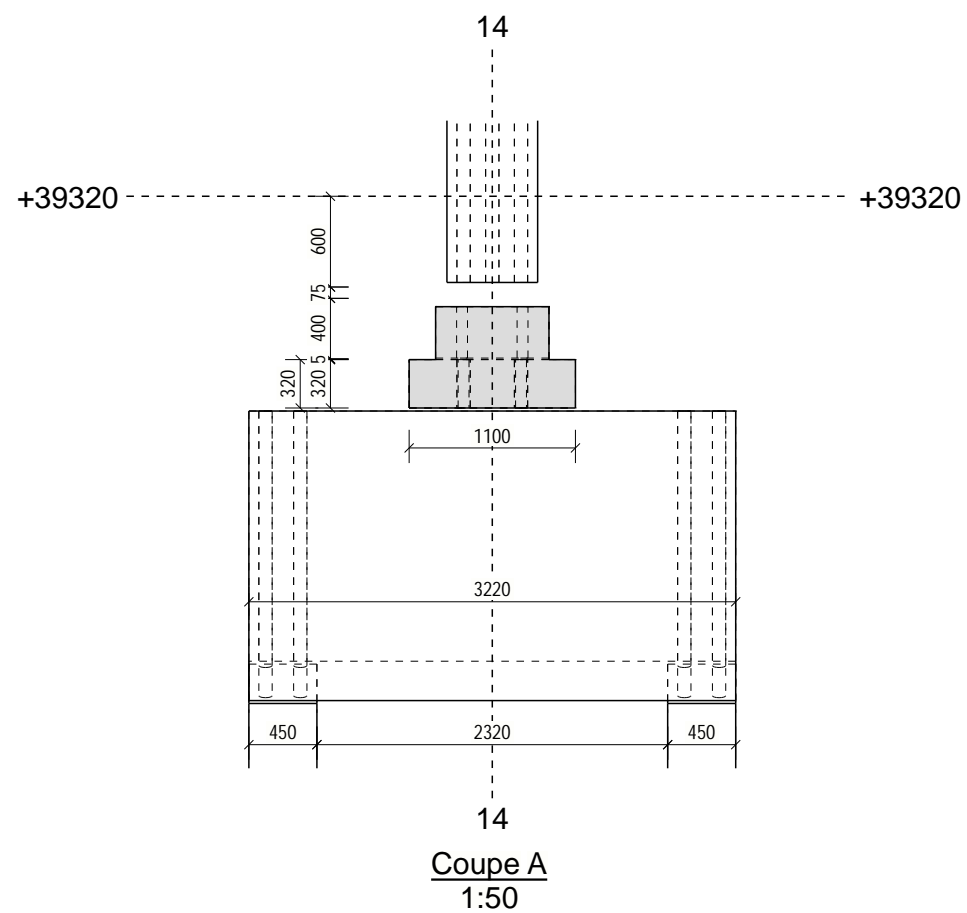

3D  
1:50



 Ergon nv/sa Marnixdreef 5 B-2500 LIER T +32 (0)3 490 04 00 F +32 (0)3 489 23 27 www.ergon.be		Tekenaar: VDA	Ingenieur: DOL
		Schaal: 1:50	Datum: 05.10.2021
Project: <b>Project 2023 - BEFIMMO - WTC Brussel</b>		Projectnummer: <b>203861</b>	Tekeningnummer: <b>DET.B</b>
Tekening: DOUBLE COLONNES AXE 14/G-F CVT +4 (+39320)		Opdrachtgever: <b>THV ZIN IN NOORD</b>	
REV.	DATUM	NAAM	WIJZIGINGEN
<b>CONTROLE AUTORITEIT</b>			<input type="checkbox"/> TER GOEDKEURING <input type="checkbox"/> AKKOORD voor PRODUCTIE <input type="checkbox"/> VOOR UITVOERING
PROJECT MANAGER	ONTWERP INGENIEUR	TEKENAAR	CONTROLE INGENIEUR
OPDRACHTGEVER / AANNEMER	ARCHITECT	STUDIEBUREAU	CONTROLE BUREAU