

PART - PC20072
4x PL8X100 - 1346 (S235JR)

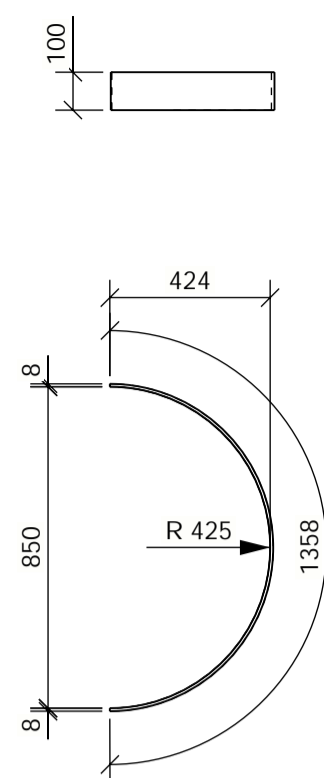

PART - PC20073
4x PL10X1050 - 1050 (S235JR)

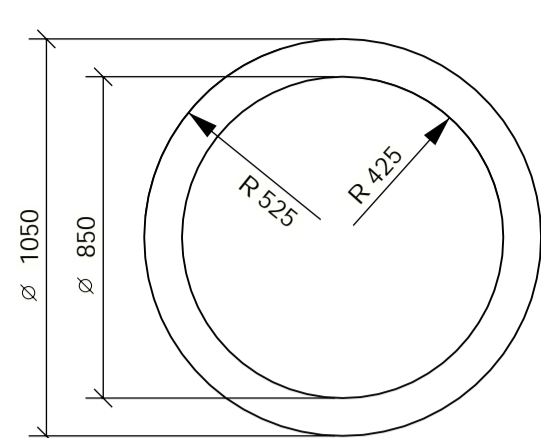

PART - PC20074
2x PL8X290 - 3619 (S235JR)

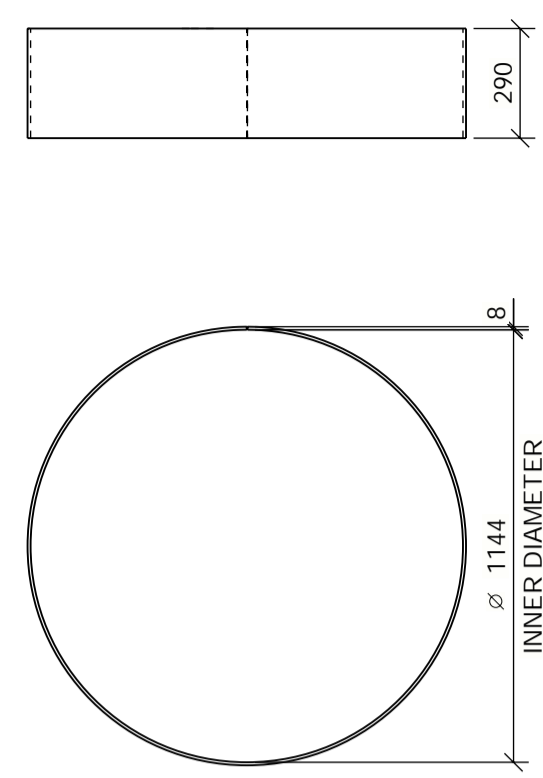

PART - PC20075
2x PL8X2046 - 4835 (S235JR)

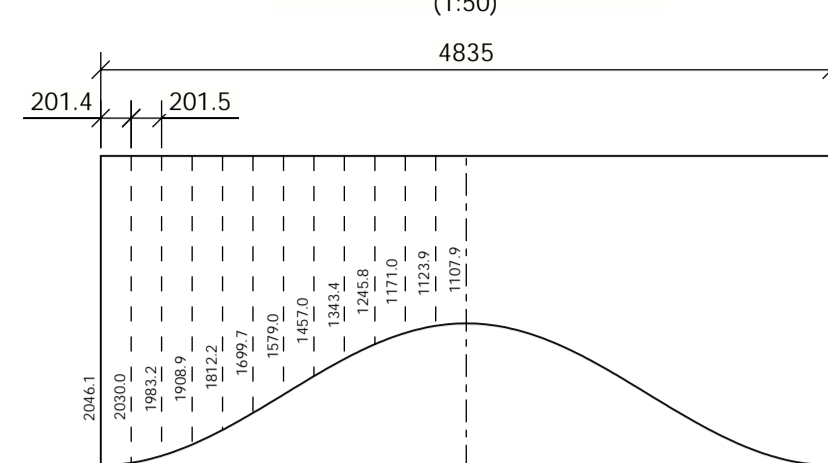

PART - PC20076
2x PL8X1852 - 4835 (S235JR)

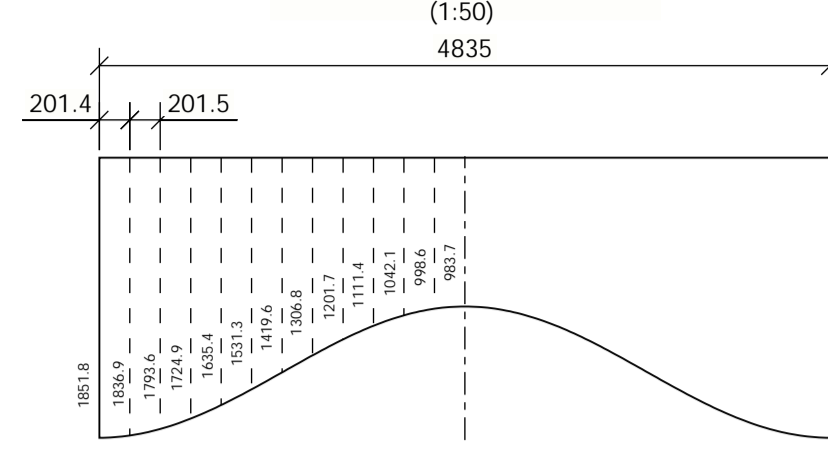

PART - PC20077
2x PL8X1532 - 4838 (S235JR)

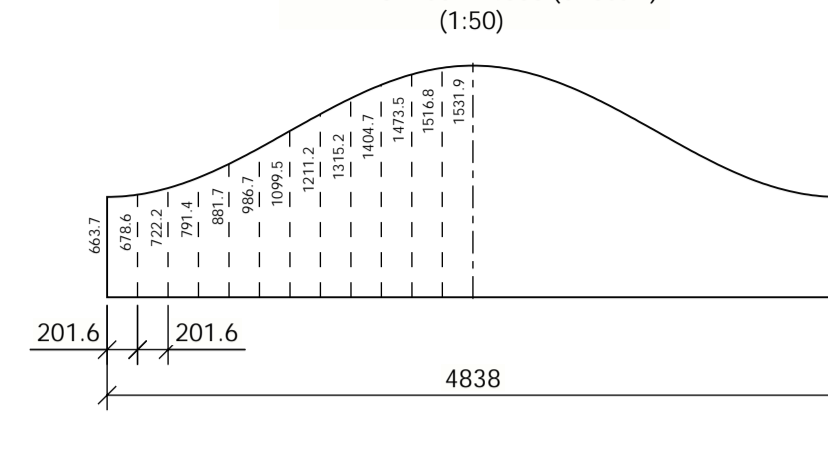

PART - PC20078
2x PL8X1782 - 4835 (S235JR)

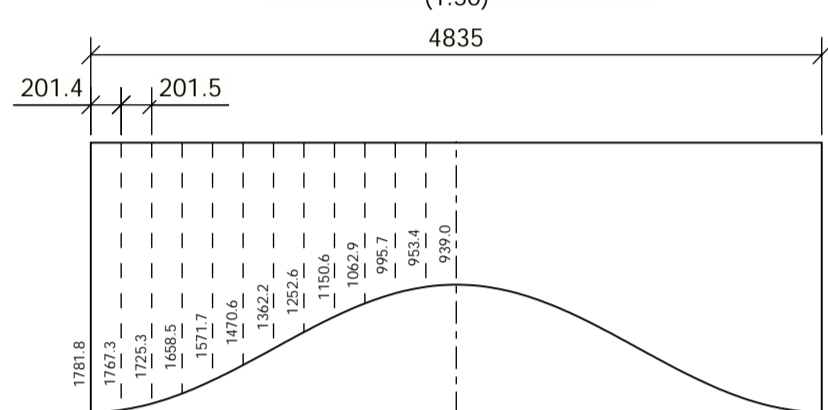

PART - PC20079
2x PL8X1519 - 4838 (S235JR)

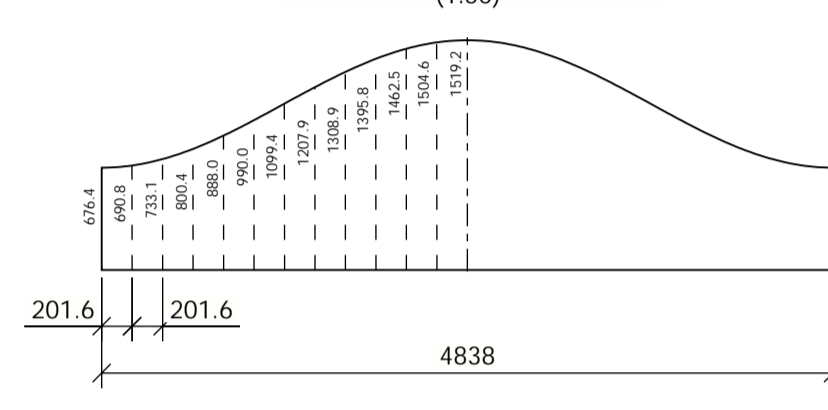

PART - PC20080
2x PL8X1715 - 4835 (S235JR)

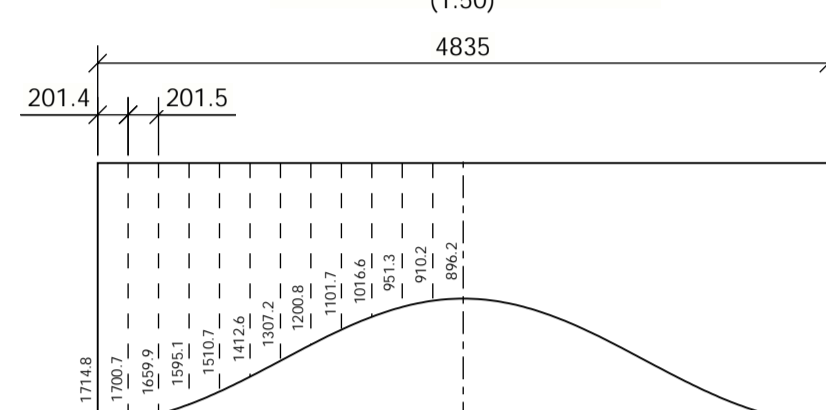

PART - PC20081
2x PL8X1507 - 4838 (S235JR)

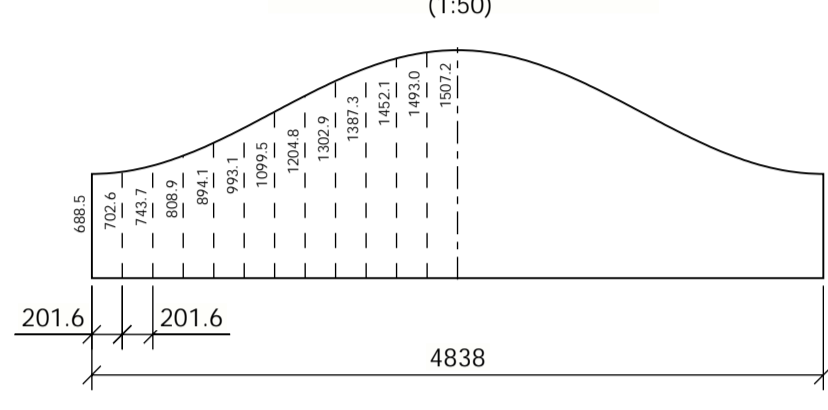

PART - PC20082
2x PL8X1651 - 4835 (S235JR)

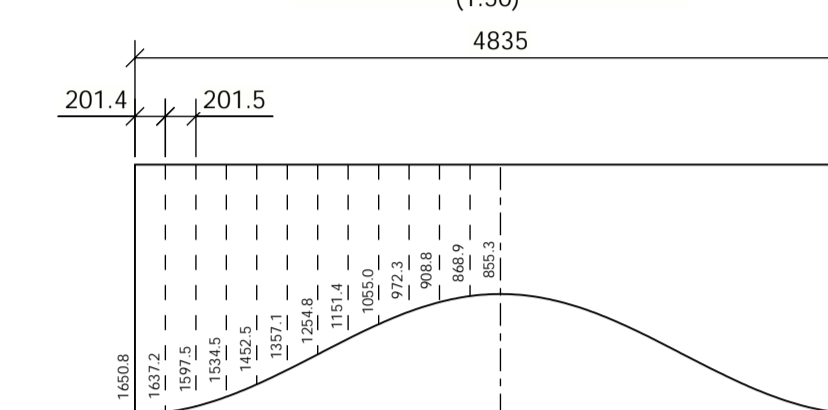

PART - PC20083
2x PL8X1496 - 4838 (S235JR)

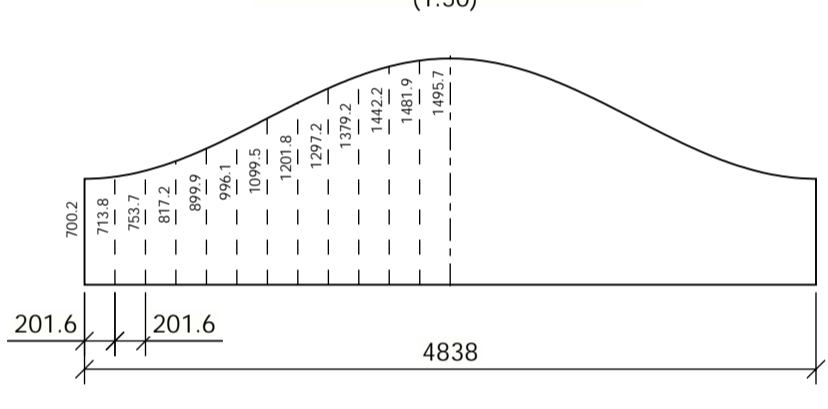

PART - PC20084
2x PL8X1590 - 4835 (S235JR)

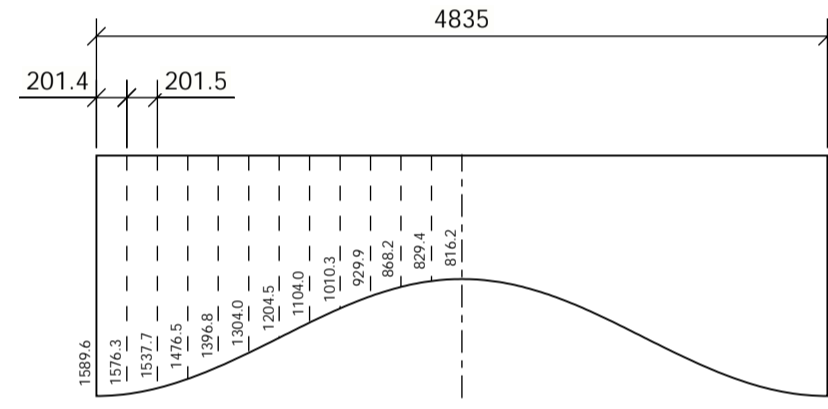

PART - PC20085
2x PL8X1485 - 4838 (S235JR)

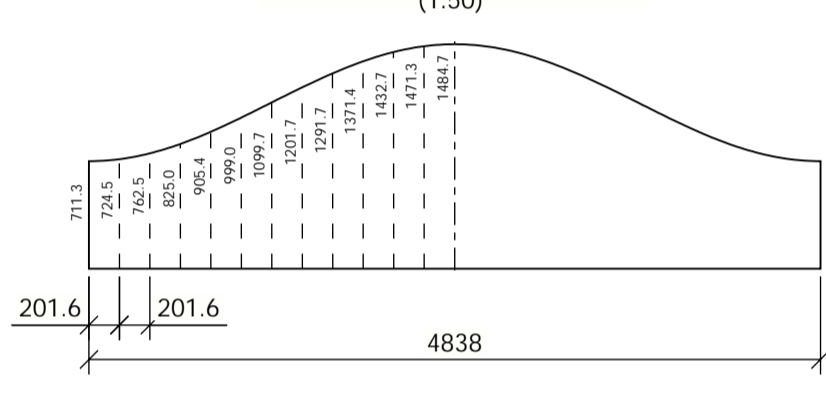

PART - PC20086
2x PL8X1531 - 4835 (S235JR)

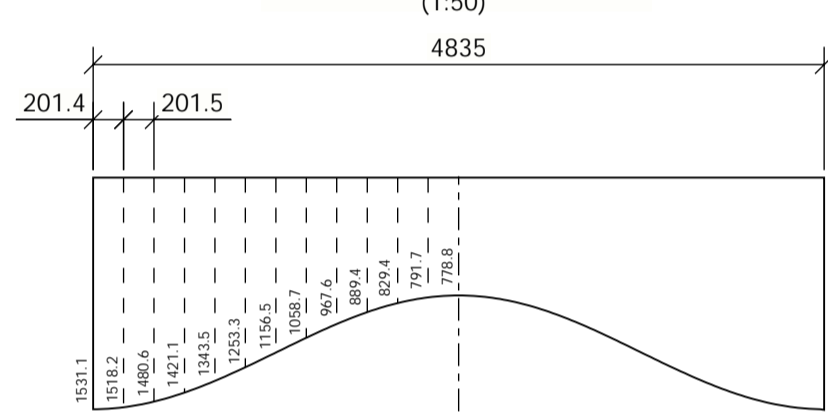

PART - PC20087
2x PL8X1474 - 4838 (S235JR)

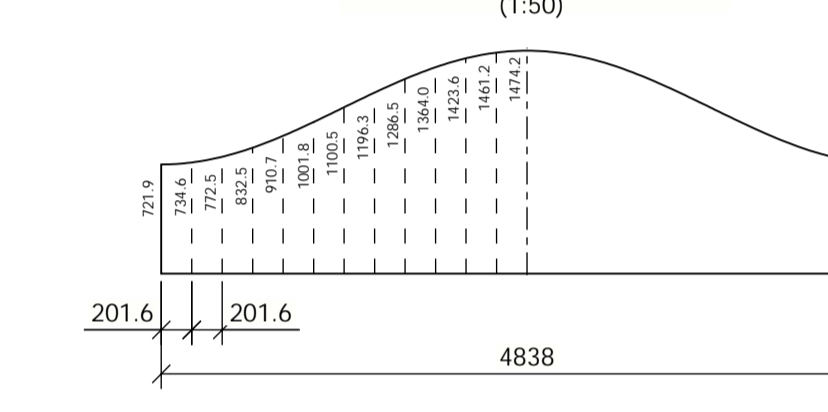

PART - PC20088
2x PL8X1475 - 4835 (S235JR)

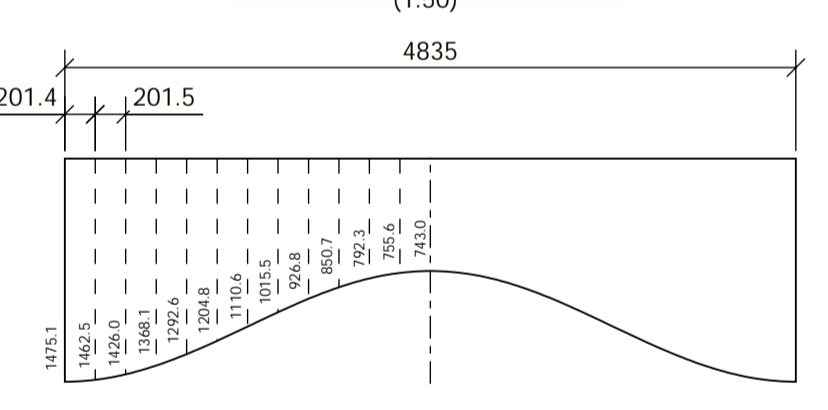

PART - PC20089
2x PL8X1464 - 4838 (S235JR)

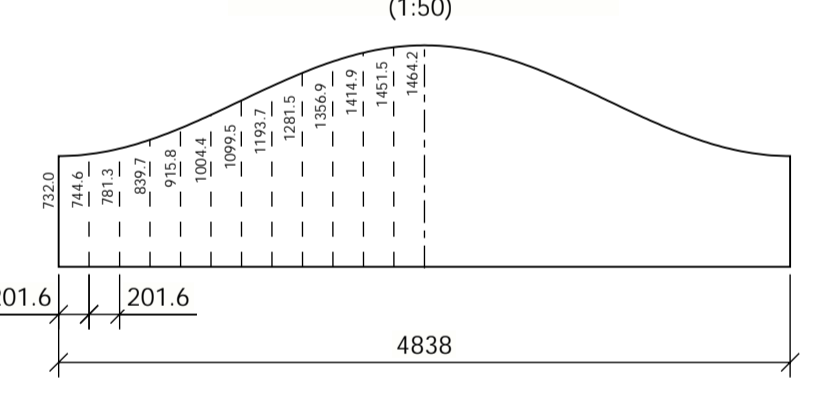

PART - PC20090
2x PL8X1422 - 4835 (S235JR)

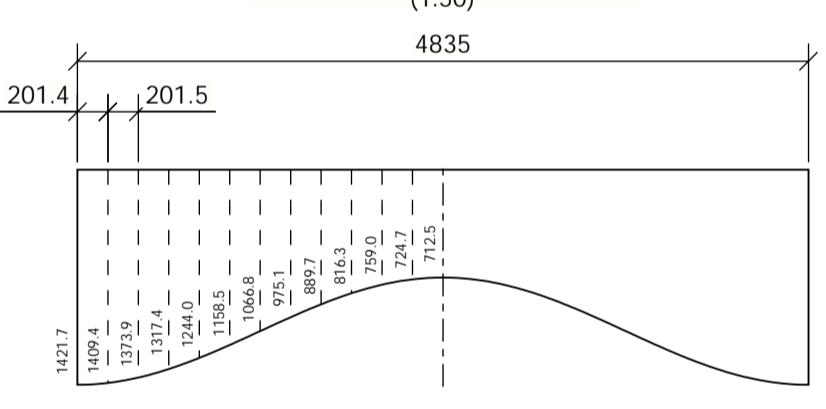

PART - PC20091
2x PL8X1455 - 4838 (S235JR)

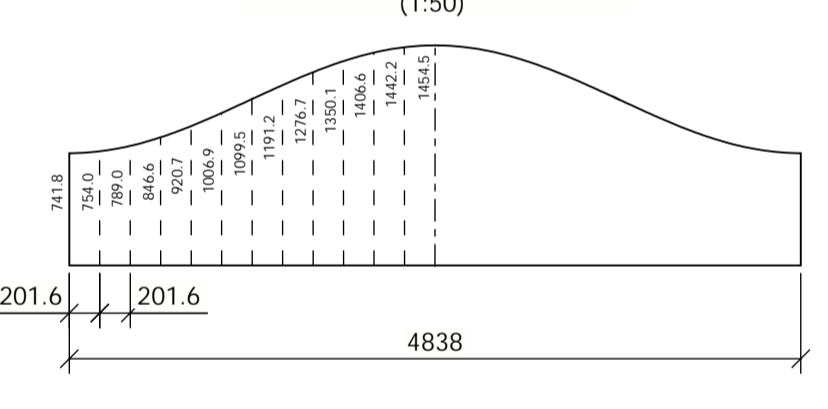

PART - PC20093
52x PL8X80 - 472 (S235JR)

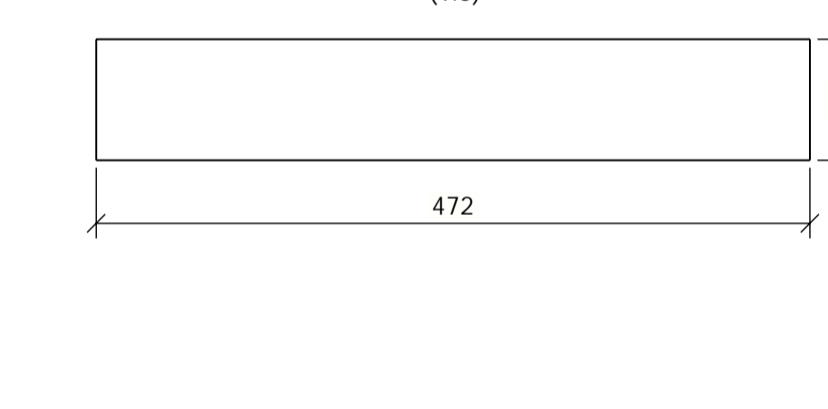

PART - PC20092
8x PL8X80 - 1750 (S235JR)

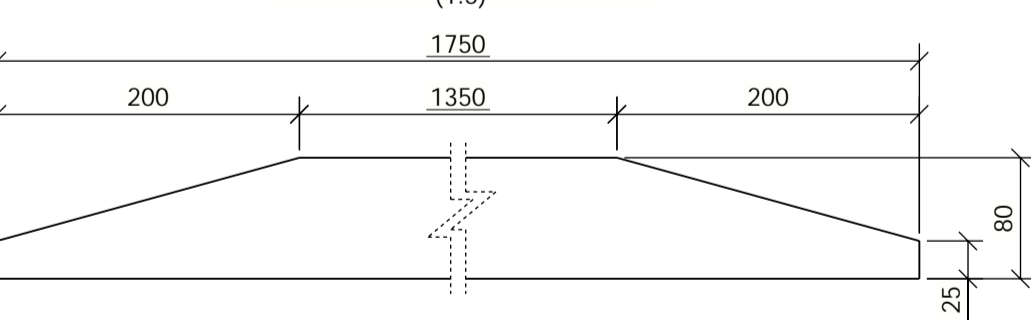

PART - PC20094
4x PL8X80 - 496 (S235JR)

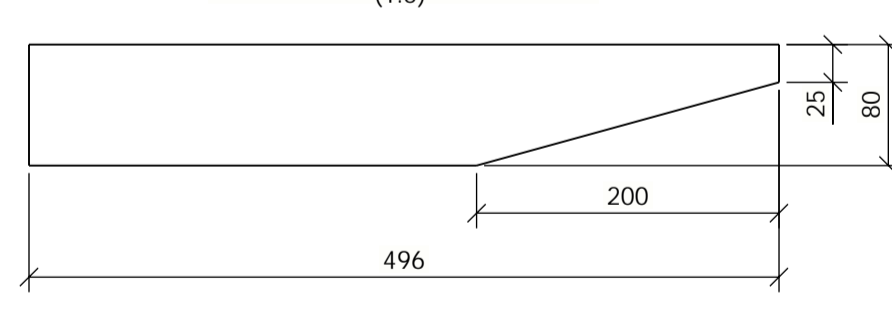

PART - PC20095
4x PL8X80 - 641 (S235JR)

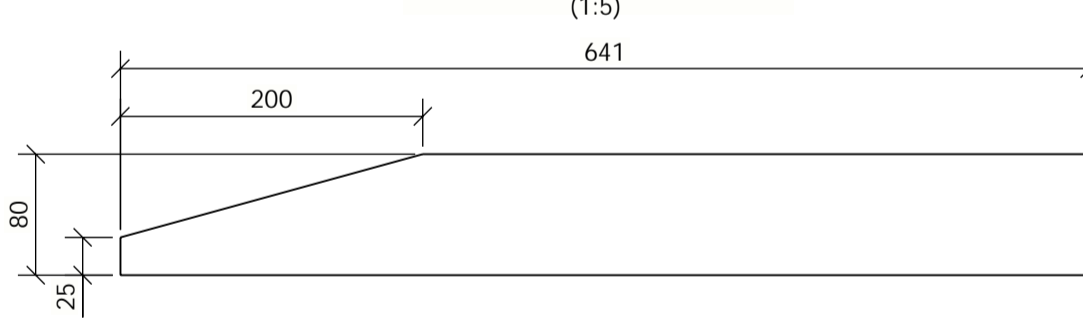

PART - PC20096
52x PL8X70 - 488 (S235JR)

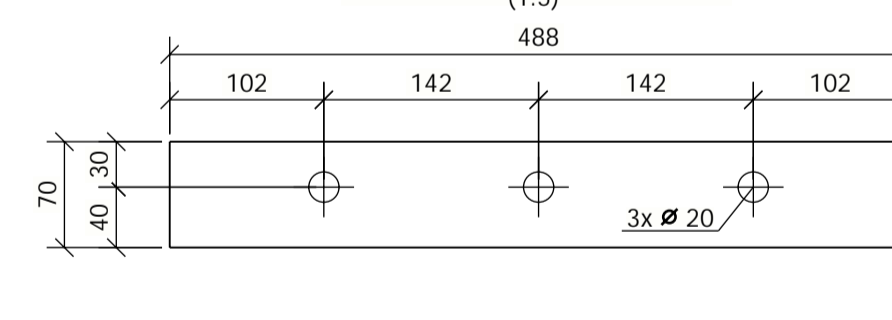

PART - PC20097
52x PL8X70 - 942 (S235JR)

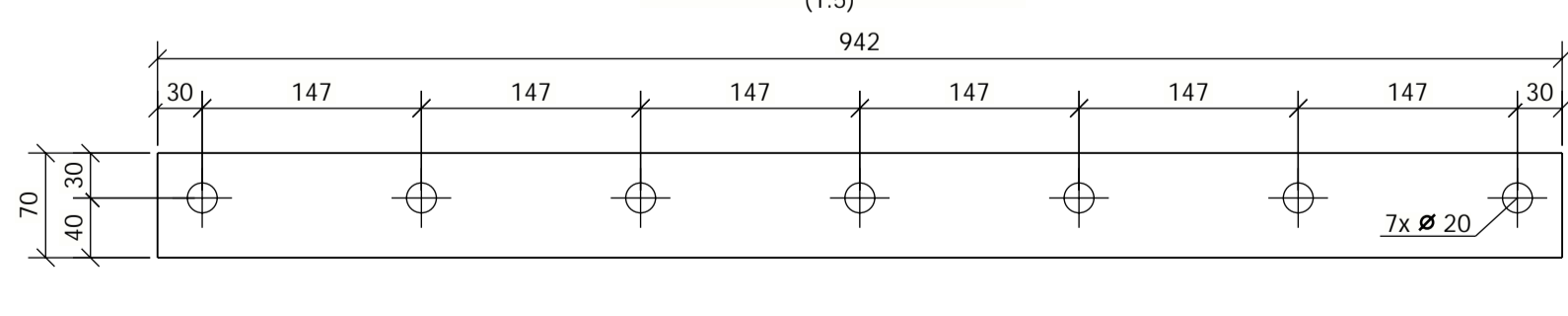

PART - PC20098
48x PL8X80 - 2050 (S235JR)

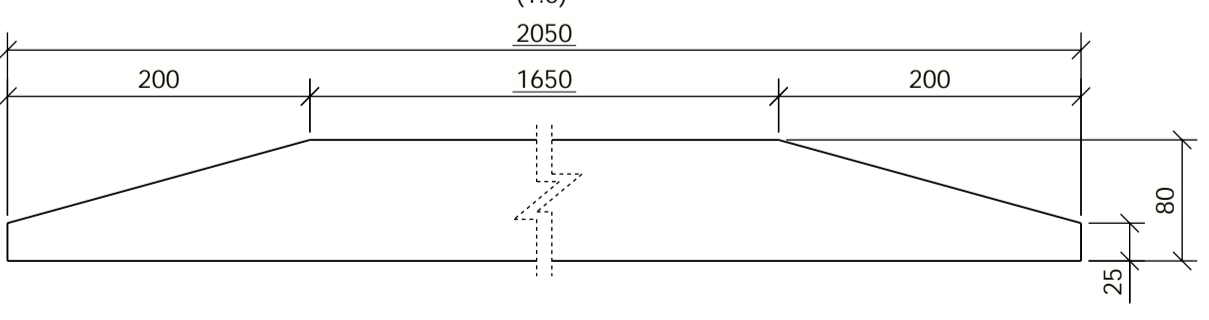

PART - PC20100
48x PL8X80 - 791 (S235JR)

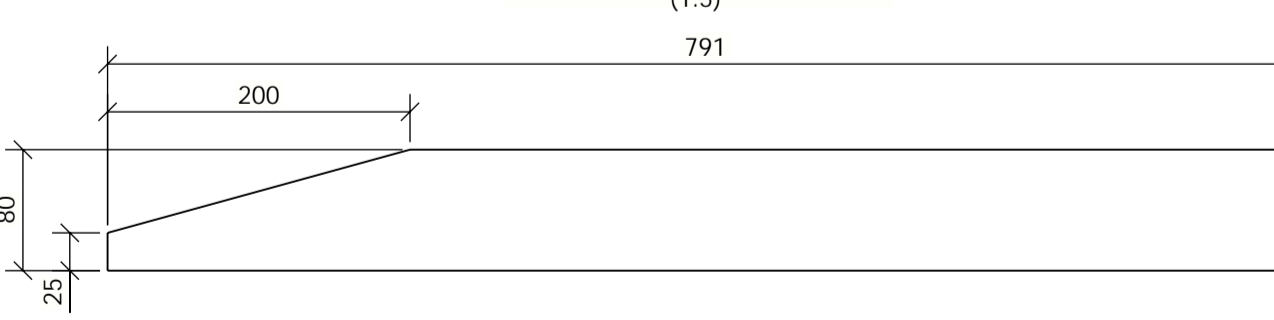

PART - PC20099
48x PL8X80 - 646 (S235JR)

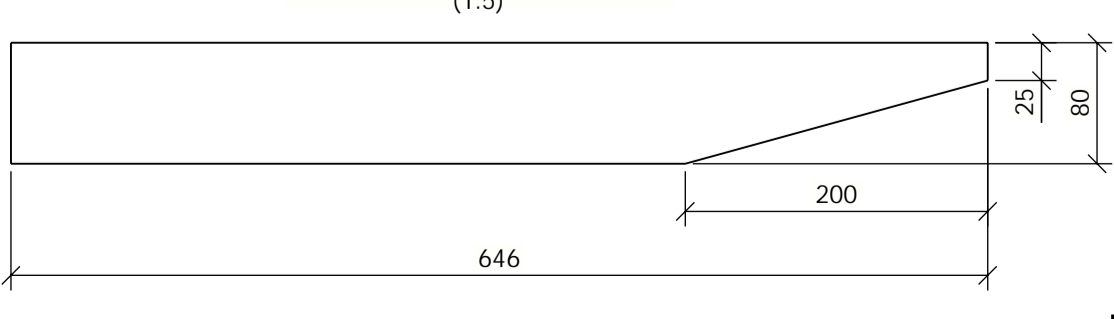

STEEL STRUCTURE EXECUTION CLASS: EXC2
TOLERANCES ACCORDING TO DIN EN ISO 13920 CLASS B/F

WELDING:
- UNLESS INDICATED OTHERWISE, ALL WELDS ARE MINIMUM 4 mm AND ARE CONTINUOUS
- ALL GIVEN WELDS DIMENSIONS ARE EUROPEAN WAY: THROAT DIMENSION,
FOR LEG SIZE MULTIPLY THROAT DIMENSION BY 1.42
- SYMBOLIC REPRESENTATION ON DRAWING TO ISO 2553
- JOINT PREPARATION ACCORDING TO EN 9692-1 AND EN 1708

DERUSTING AND COATING ACCORDING TO:
- 903254_ZZZ01_ZZ01_BEC01_00004_OU10198090 - PAINTING AND CONSERVATION
- 903254_ZZZ01_ZZ01_BEC01_00007_OU10200593 - PAINTING SYSTEMS