

LIST OF ASSEMBLED PIECES				
MARK	QTY	FINISH	WEIGHT	
08F5	1			
08A52	1	N	54	
08A53	1	N	42	
08B58	1	P2UN	1892	
08B71	1	N	414	
TOTAL WEIGHT:			2402	

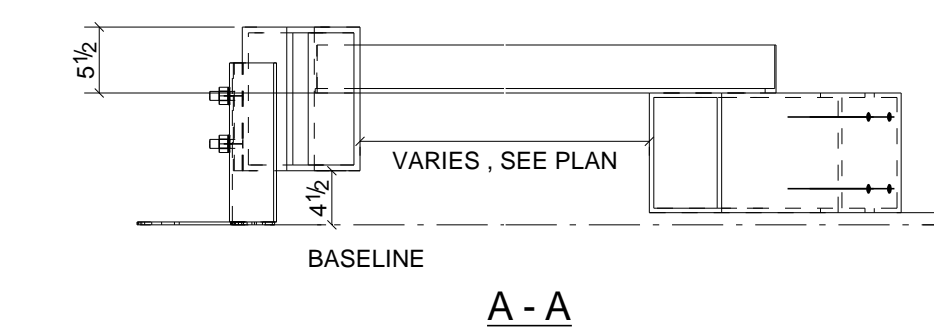
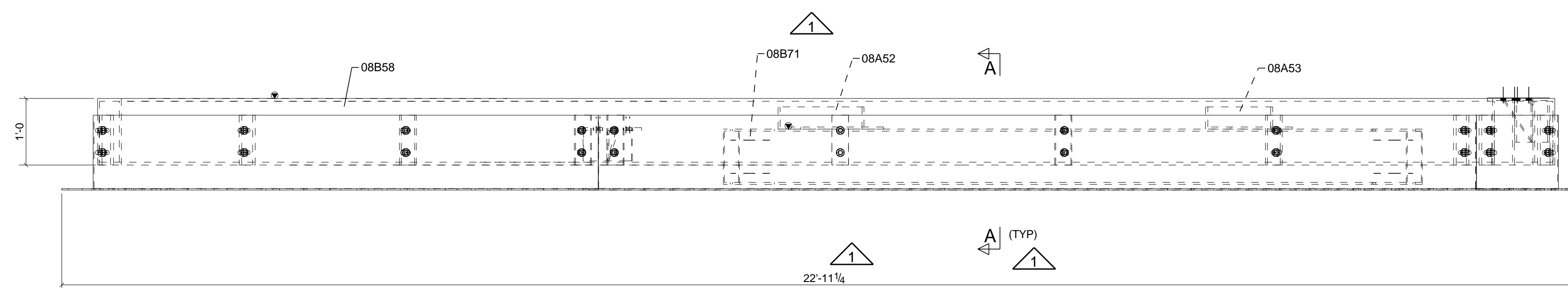
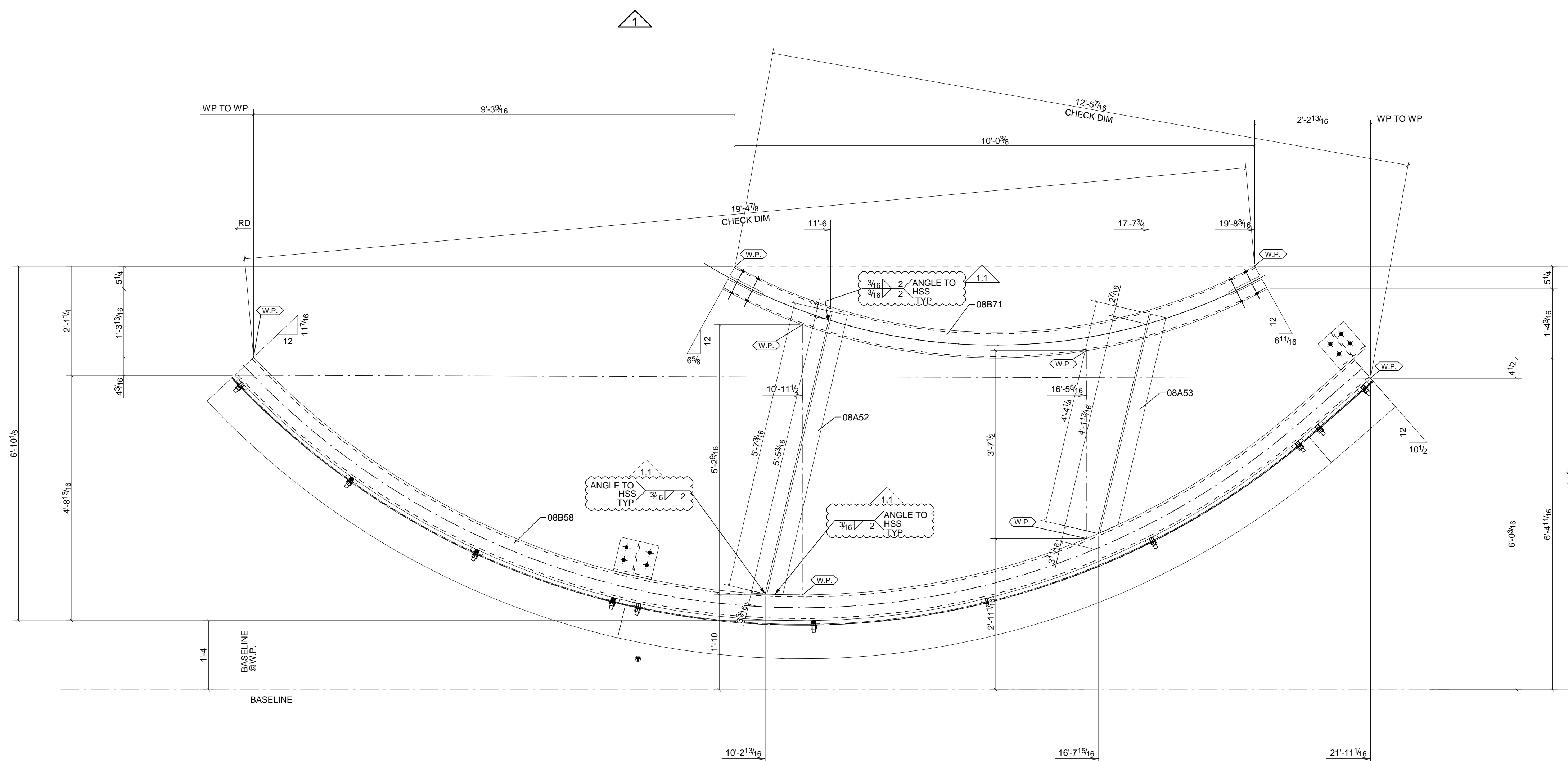

1 FRAME MARK: 08F5

MATERIAL: A36 U.N.O. SHOP NOTCH / COPE: STANDARD  
 BOLTS: A490N-TC U.N.O. HOLES: 15/16\" DIA U.N.O.  
 WELDS: AS NOTED MARK STYLE: STANDARD  
 FINISH:  
 PRIMER: NO PAINT  
 SURF. PREP: SSPC-SP2 E802

Fargo, ND  
 Mandan, ND  
 Rapid City, SD  
 Billings, MT  
 TrueNorthSteel.com

BACK CHARGES WILL NOT BE HONORED WITHOUT PRIOR AUTHORIZATION  
 These drawings have been prepared in accordance with the AISC Code of Standard Practice

PBI0493  
 Job No:  
 HSS  
 Drawn By:  
 MTG  
 Checked By:  
 08F5  
 Sheet No.

Barnard Office Complex  
 RoyalWolf May Bozeman, MT

REV	DATE	ISSUED FOR APPROVAL	REMARKS	BY
1.1	2023/09/08	RE-IFF, WELD REVISED		MT
1	2023/06/29	RE-IFF, LENGTH REVISED		MT
0	2023/06/01	ISSUED FOR FABRICATION		MT
A	2023/05/04	ISSUED FOR APPROVAL		MT

