

AXIS B 1:75

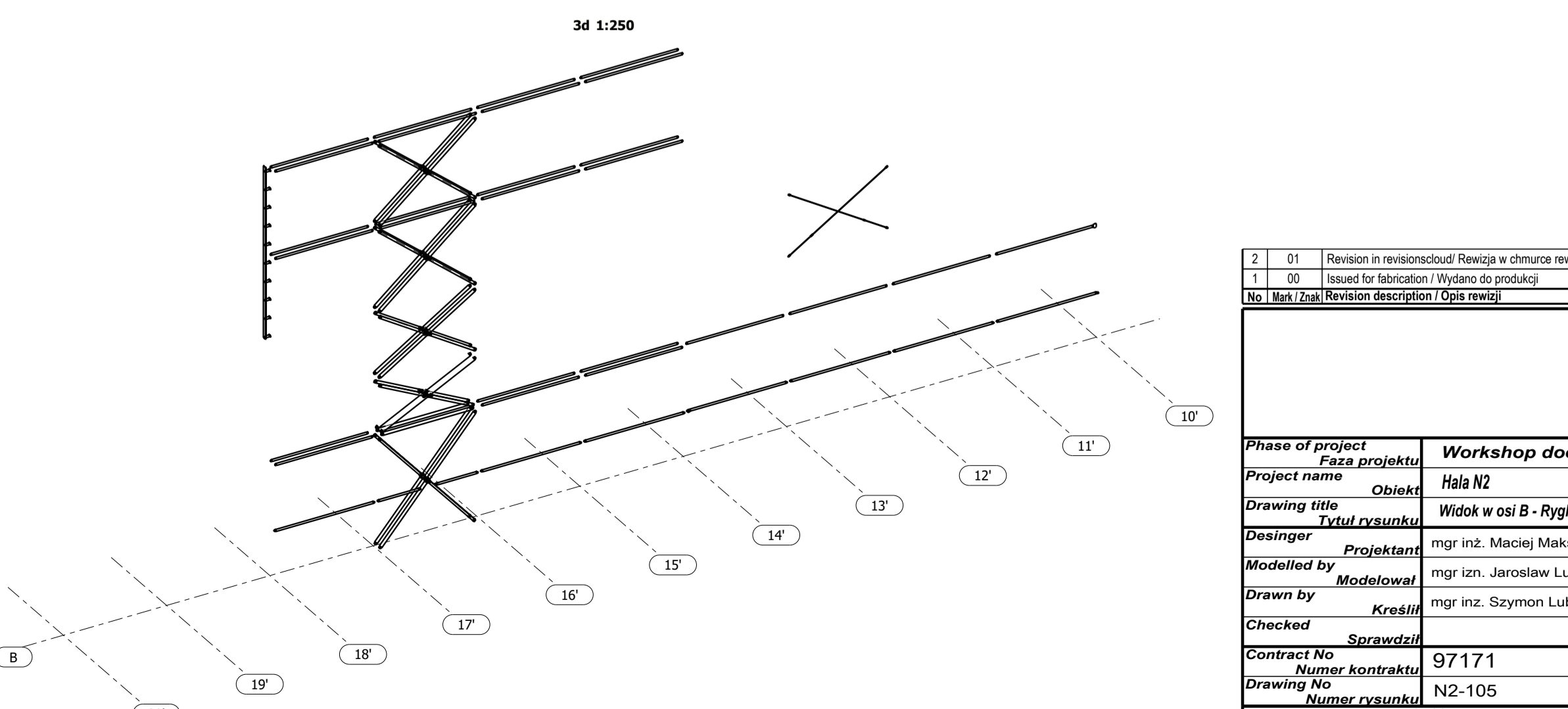
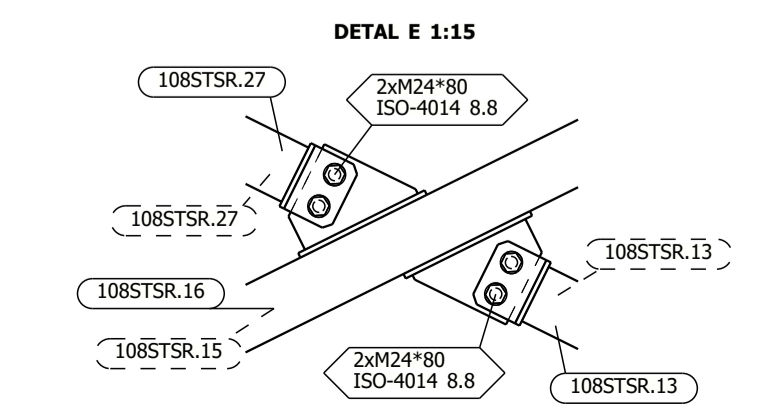
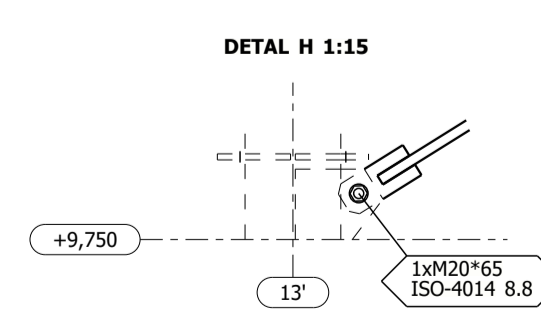
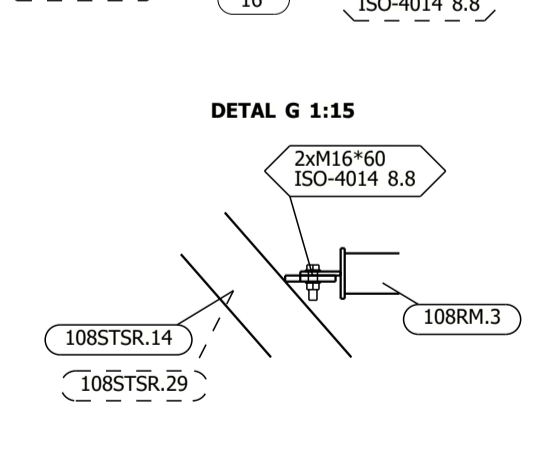
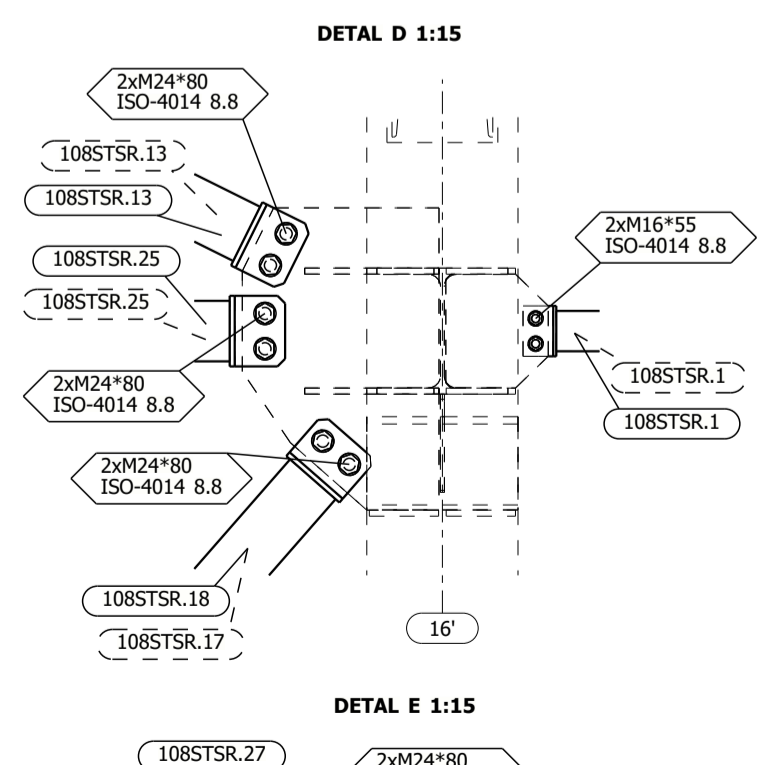
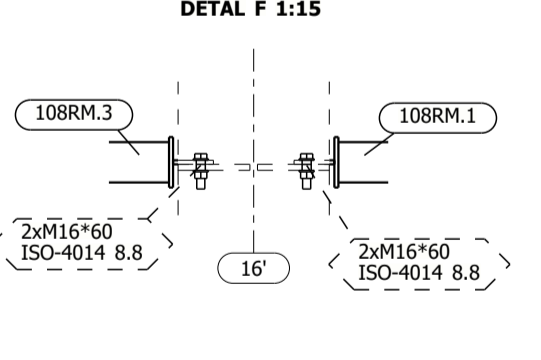
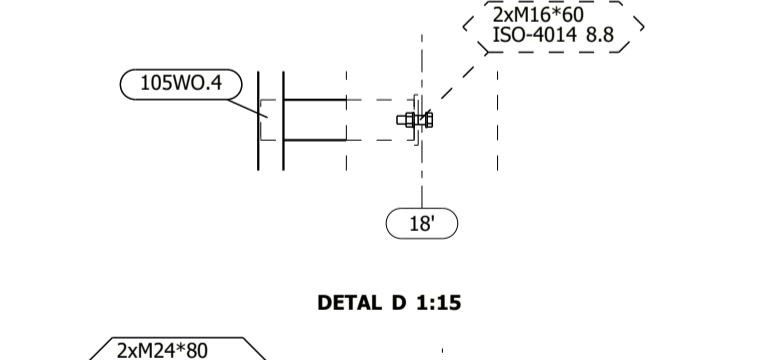
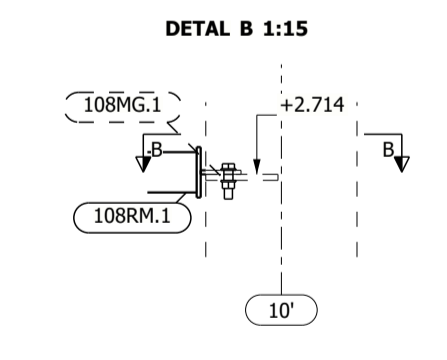
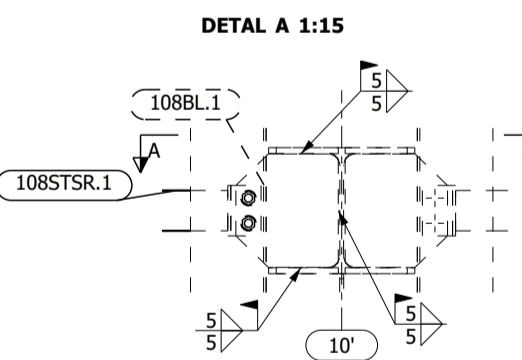
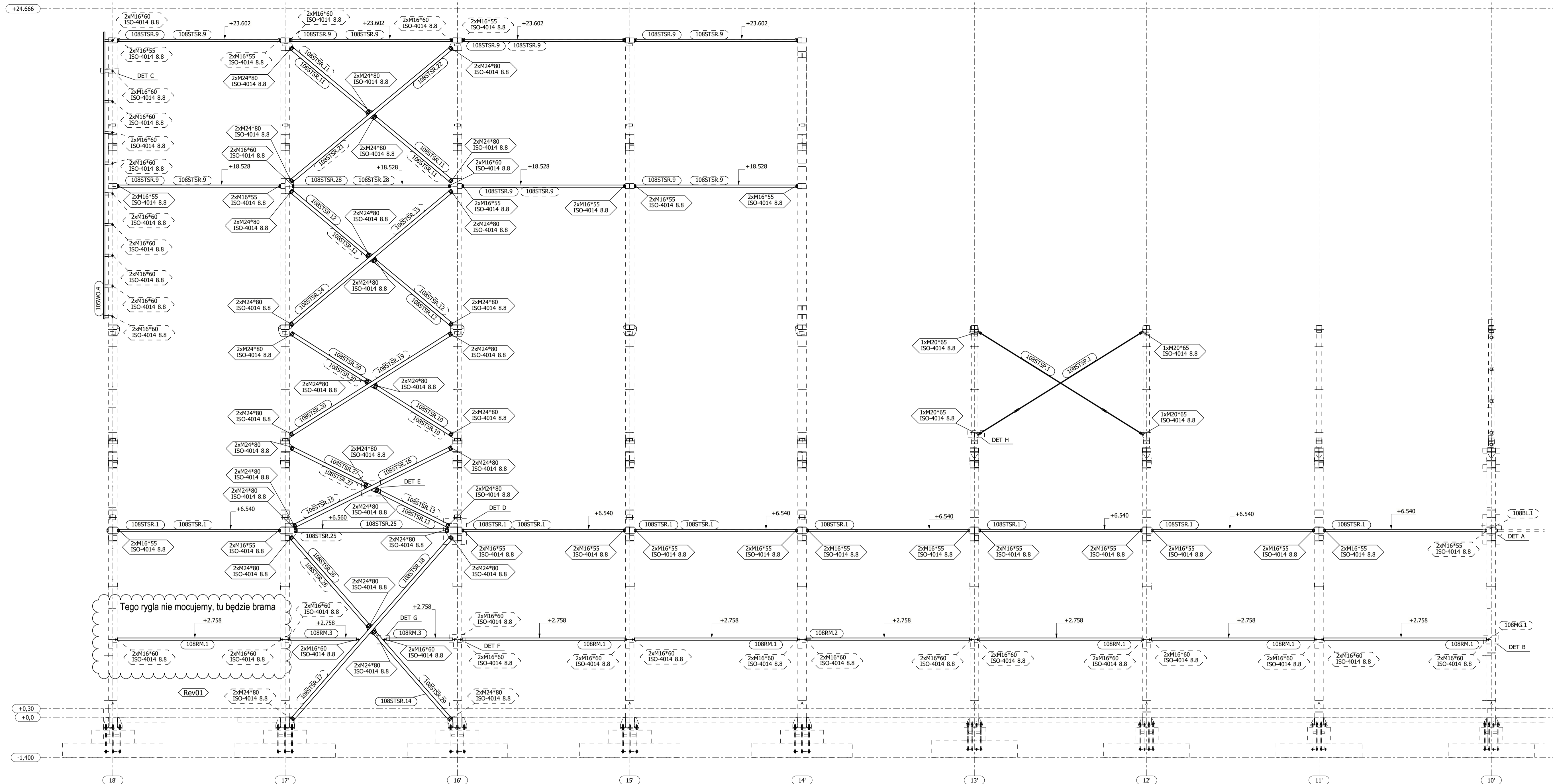

**BOLTS, NUTS & WASHER REPORT**  
 LISTA ŚROB, NAPRĘTEK, PODRĄDEK I ŚMORZNI

Type	Size	Qty	Norm	Grade/Material
Typ	Wymiar	Ilość	Norma	Klasa/Materiał
BOLT	M16	128	ISO 4014 8.8	A4-70
BOLT	M24	80	ISO 4014 8.8	A4-70
BOLT	M20	1	ISO 4014 8.8	A4-70
NUT	M16	128	ISO 4014 8.8	A4-70
NUT	M24	80	ISO 4014 8.8	A4-70
NUT	M20	1	ISO 4014 8.8	A4-70
WASHER	M16	128	ISO 4014 8.8	A4-70
WASHER	M24	80	ISO 4014 8.8	A4-70
WASHER	M20	1	ISO 4014 8.8	A4-70

2	01	Revision in revisionscloud! Rewizja w chmurze rewizyjnej	SL	2023-09-13
1	00	Issued for fabrication / Wydano do produkcji	SL	2023-05-08
No / Mark / Znak / Revision description / Opis rewizji				

**PROMOSTAL**  
 konstrukcje stalowe steel constructions  
 ul. Fabryczna 7/29  
 16-020 Czarna Białostocka  
 tel: +48(085) 876 86 01  
 fax: +48(085) 876 86 02

Phase of project / Faza projektu		Workshop documentation/Dokumentacja warsztatowa		
Project name / Nazwa projektu	Objekt	Hala N2		
Drawing title / Tytuł rysunku	Widok w osi B - Ryglówka, słupzenia, wsporniki obudowy			
Designer / Projektant	mgr inż. Maciej Maksimowicz	Scale / Skala	Skala 1:15 1:75 1:250	
Modelled by / Modelował	mgr inż. Jarosław Luba	Issued / Wydany	2023-05-08	
Drawn by / Narysował	mgr inż. Szymon Lubas	Checked / Sprawdził		
Contract No / Numer kontraktu	97171	Drawing No / Numer rysunku	N2-105	Revision No / Numer rewizji
				01

**A1**  
840/504