

REF. NUMBER
ABM300

BILL OF MATERIAL

QTY	SHIPPING BILL			SHOP BILL					
	NO.	DIRECTION MARK	NO.	SHAPE	MATERIAL GRADE	LENGTH	ASSY. MARK	REMARKS	WEIGHT
20	1	20B104		BEAM					
			1	W21X44	A992	30'-4 3/4"	20B104	Ref 220R-345	1345
			4	L3X3X1/4	A36	0-3"	a526		5
			1	PL3/8"X3 1/2"	A36	1-0"	p16		4
			2	PL1/4"X4"	A36	0-4"	p33		2
			4	PL3/8"X3 1/2"	A36	0-9"	p36		13
			2	PL3/8"X12"	A36	1-10 5/8"	p510		58
			5	3/40 A325N_TC BOLT		0-2"		Site	
			12	10 A325SC_TC BOLT		0-2 1/2"		Site	
TOTAL WEIGHT THIS DRAWING									1428

PREPARE SURFACES FOR SLIP-CRITICAL CONN. WHERE INDICATED. DO NOT PAINT AREAS OF SC CONNECTION 1 1/2" FROM CENTER OF HOLES

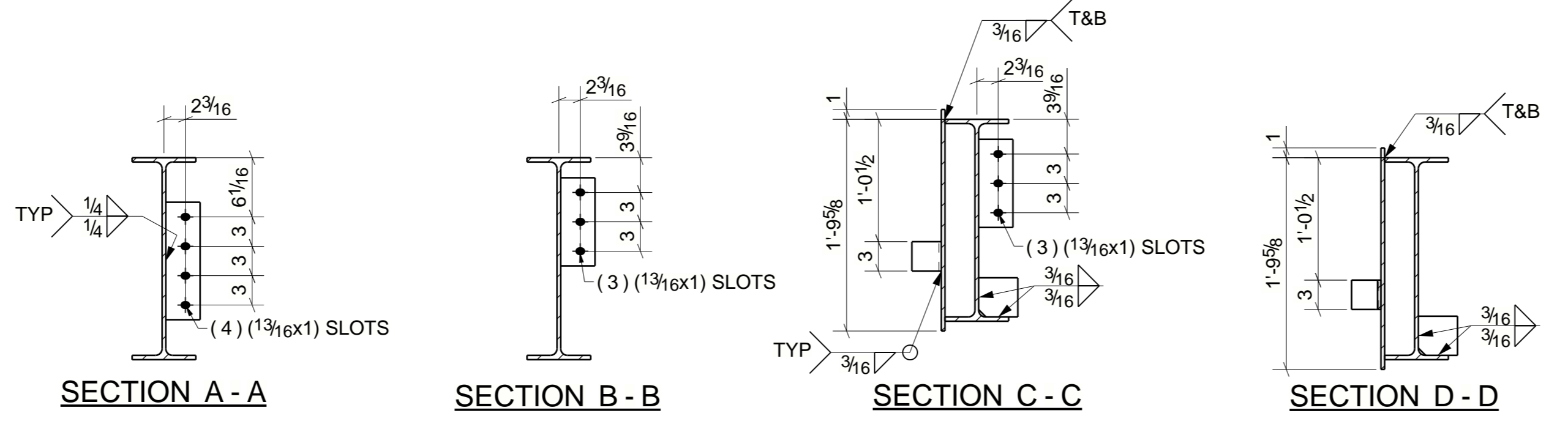
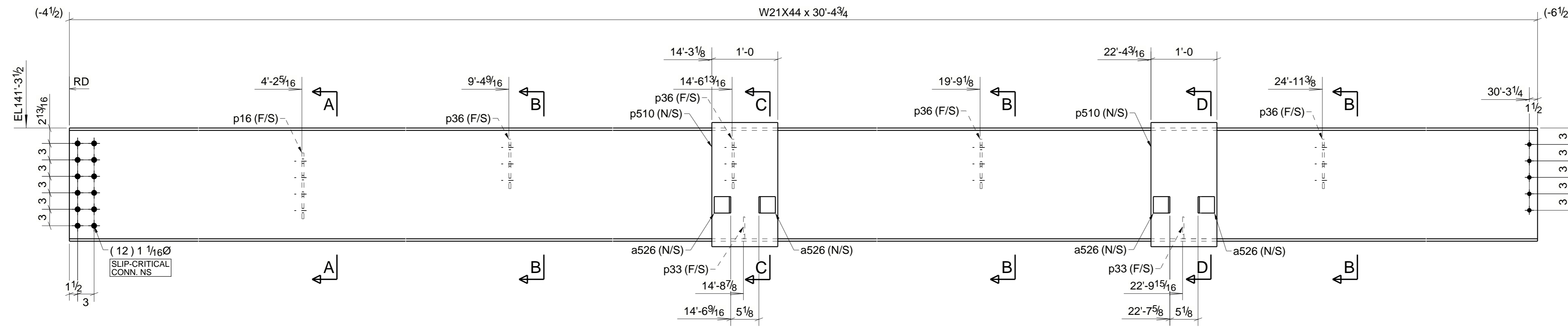

ONE - BEAM - 20B104