

QTY	SHIPPING BILL		SHOP BILL					REMARKS	WEIGHT
	NO.	DIRECTION MARK	NO.	SHAPE	MATERIAL GRADE	LENGTH	ASSY. MARK		
20	1	20B123		BEAM				SQ-2	
			1	W14X22	A992	9'-7 1/4"	20B123	NO PAINT	212
			3	L3X3X1/4	A36	1-11 3/8"	a536		29
			5	L3X3X1/4	A36	1-9 1/2"	a537		44
			2	L3X3X1/4	A36	1-10 1/4"	a962		18
			5	PL1/4X4"	A36	0-4"	p33		6
			3	PL3/8X3 1/2"	A36	0-9"	p36		10
			1	PL3/8X3 7/16"	A36	0-9"	p226		3
			1	BPL1/4"X8 1/2"	A36	7-9 1/2"	pb111		56
			1	BPL1/4"X8 1/2"	A36	5-4 1/2"	pb171		37
			5	1/20 A307 BOLT		0-1 1/4"		Workshop	1
			6	3/40 A325N_TC BOLT		0-1 3/4"		Workshop	3
TOTAL WEIGHT THIS DRAWING									419

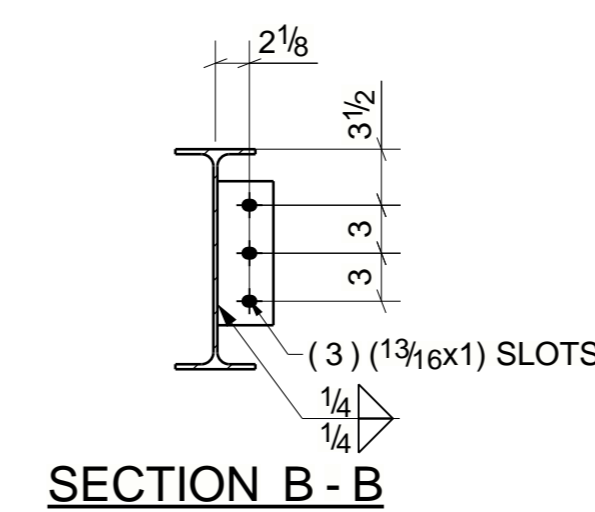
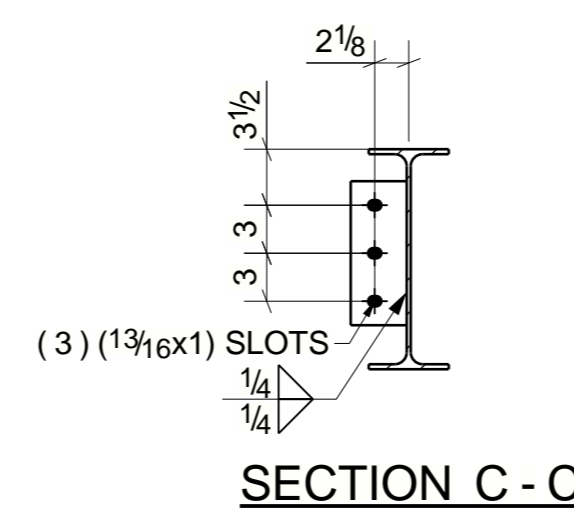
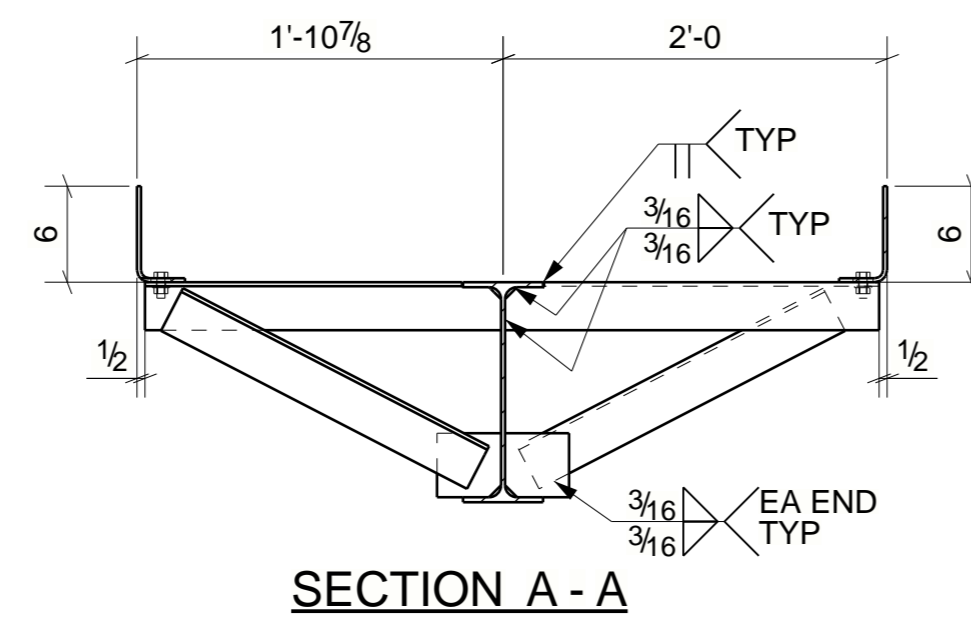
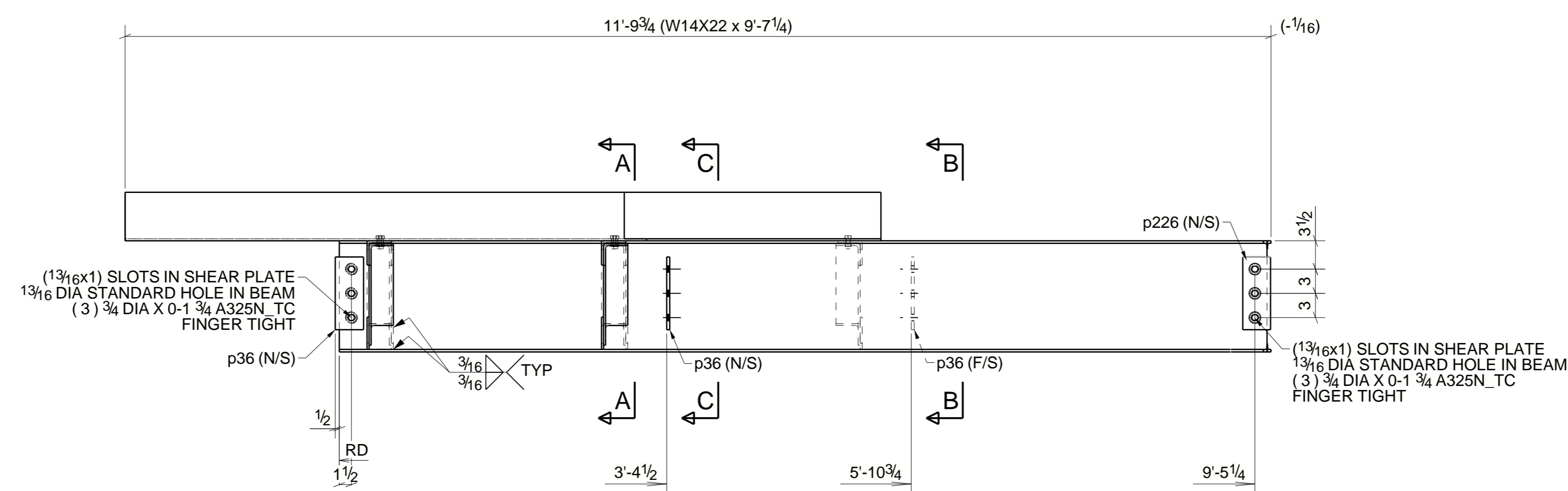
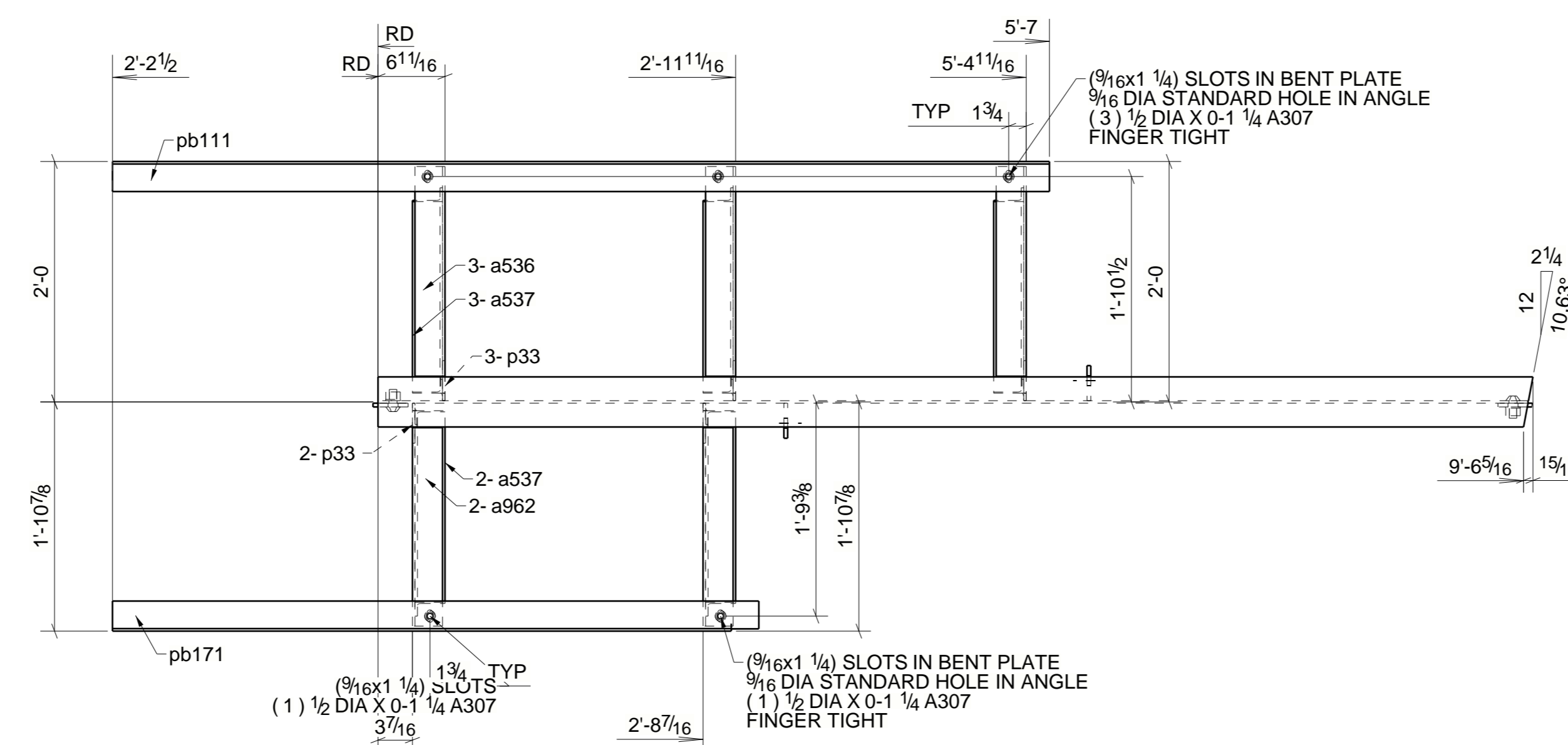

ONE - BEAM - 20B123