

truss		
8 x E1	C160X1.7	L = 3875.5
4 x E2	C160X3.0	L = 7191.0
4 x E3	C160X2.5	L = 7748.0
4 x E4	C160X2.5	L = 7748.0
8 x E5	C160X1.7	L = 8990.0
8 x E6	C160X2.0	L = 8990.0
4 x E9	C160X1.7	L = 4517.0
4 x E10	C160X1.7	L = 4517.0
4 x E11	C160X3.0	L = 7191.0
8 x E45	C160X2.0	L = 3878.0
4 x E53	C160X2.5	L = 8273.0
4 x F25	C130X2.5	L = 1791.0
4 x F26	C130X1.5	L = 1358.0
8 x F27	C130X2.0	L = 1786.0
40 x F28	C130X1.2	L = 1358.0
8 x F29	C130X1.7	L = 1786.0
20 x F30	C130X1.2	L = 1786.0
4 x F31	C130X1.5	L = 1786.0
4 x F32	C130X2.5	L = 1786.0
8 x F33	C130X1.2	L = 1494.0
4 x F35	C130X2.5	L = 1358.0
8 x F36	C130X1.5	L = 1506.5
4 x F38	C130X2.0	L = 1865.0
4 x F39	C130X1.5	L = 1454.0
4 x F40	C130X1.2	L = 2154.0
4 x F41	C130X1.2	L = 1757.0
4 x F42	C130X1.2	L = 2070.0
2 x F47	C130X2.0	L = 2055.5
4 x F103	C130X1.2	L = 1166.0
frame		
4 x Q4	SA320X3.0	L = 7986.5
4 x Q21	SA320X4.5	L = 7986.5
4 x Q22	SA320X4.0(S***L)	L = 11573.0
4 x Q38	SA320X5.0(S***L)	L = 11573.0

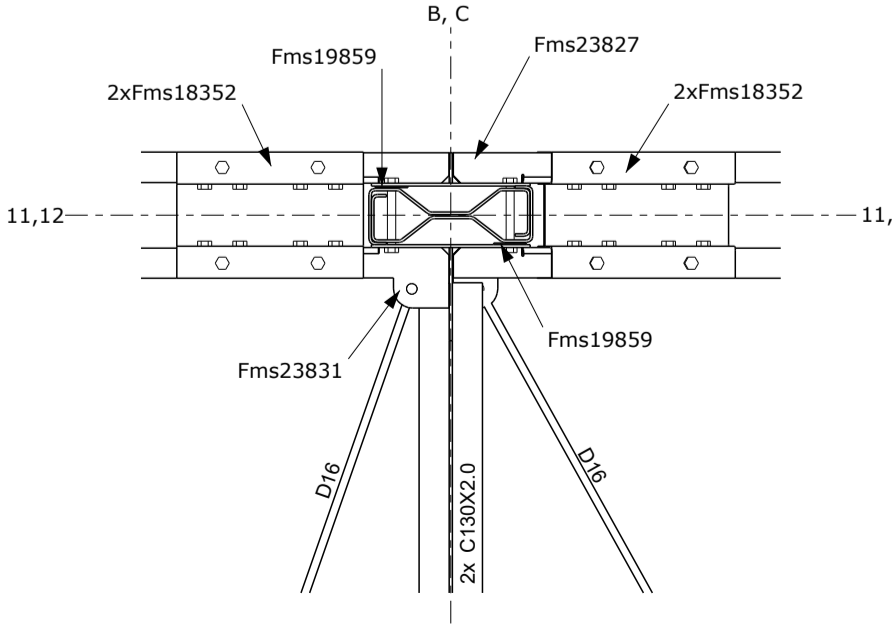
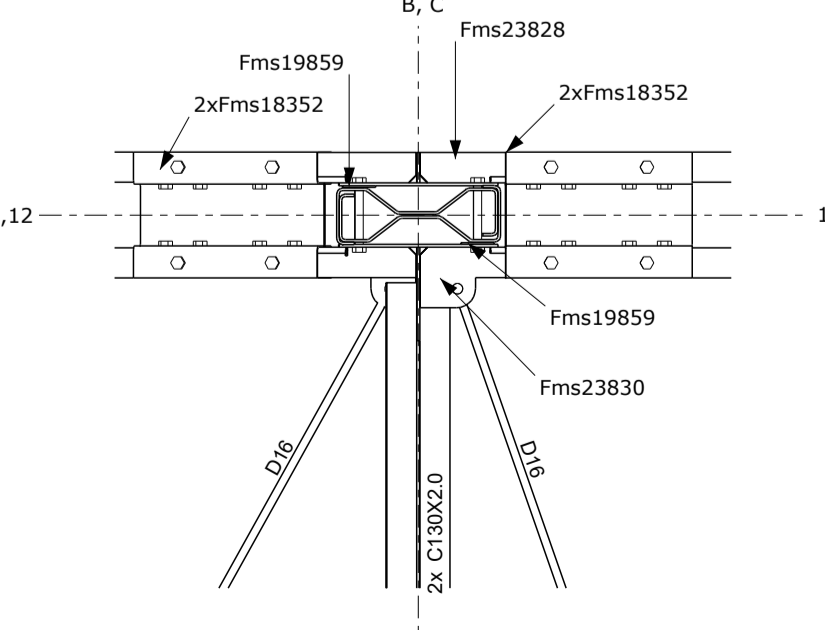
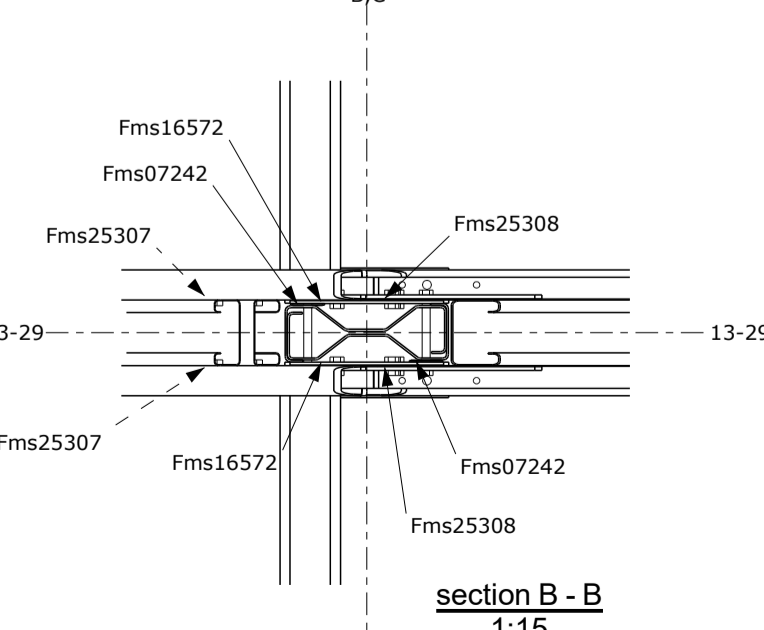
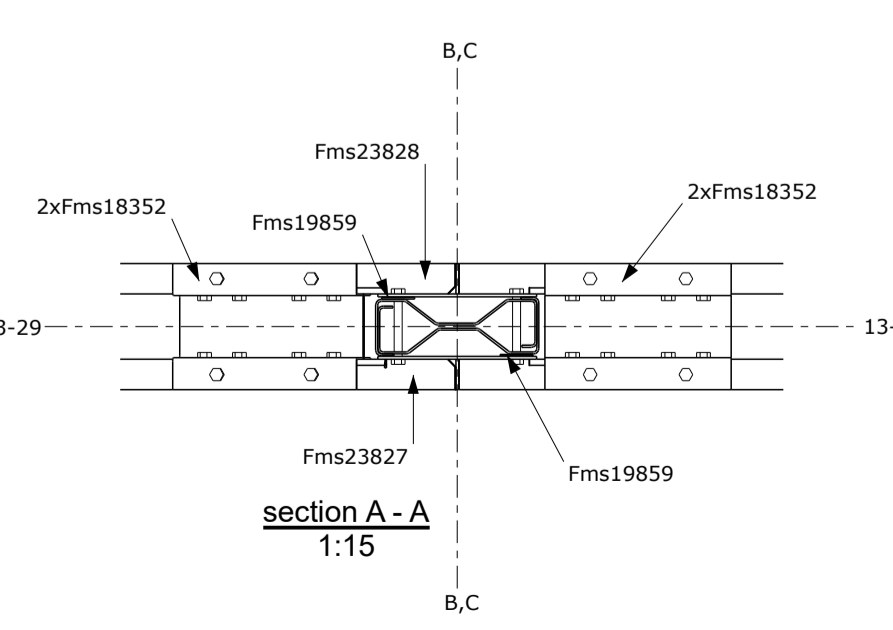
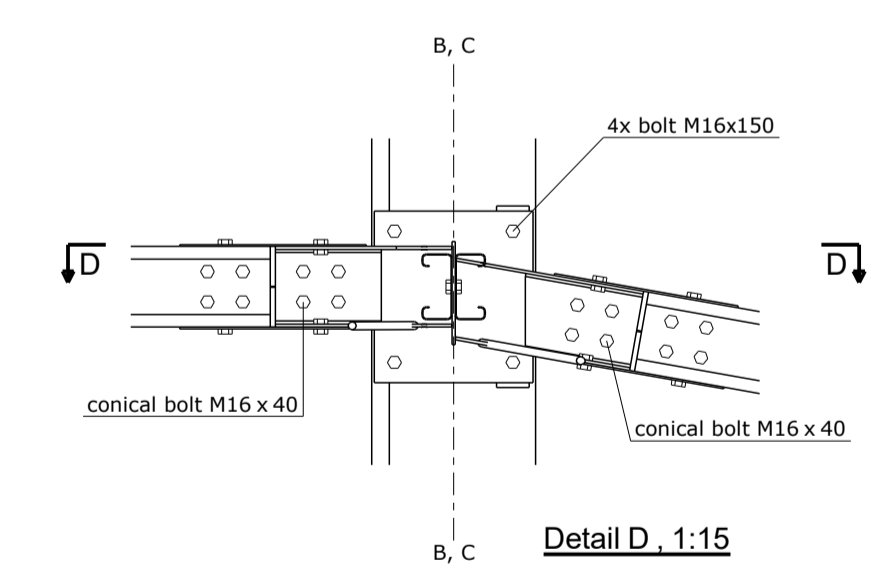
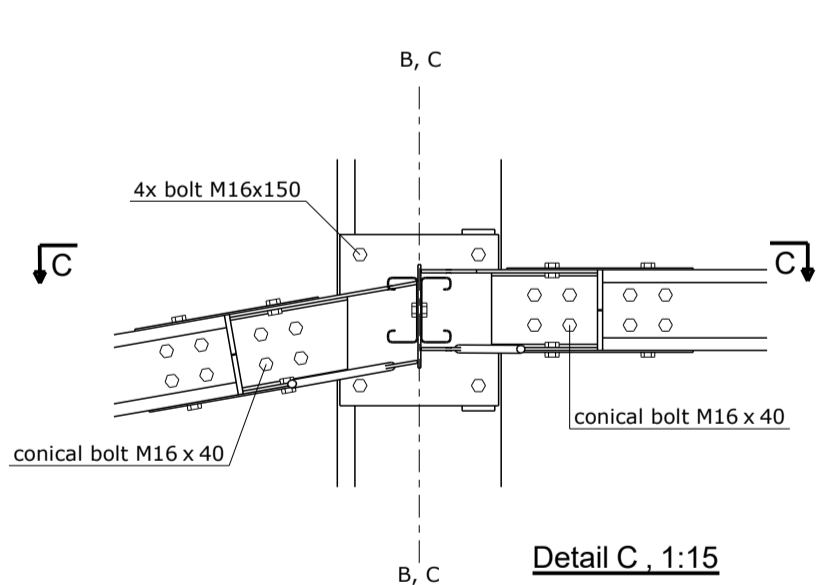
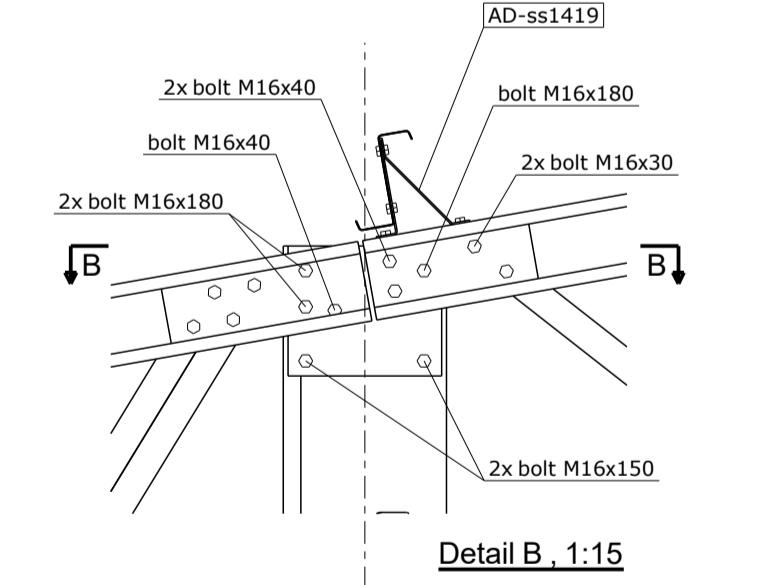
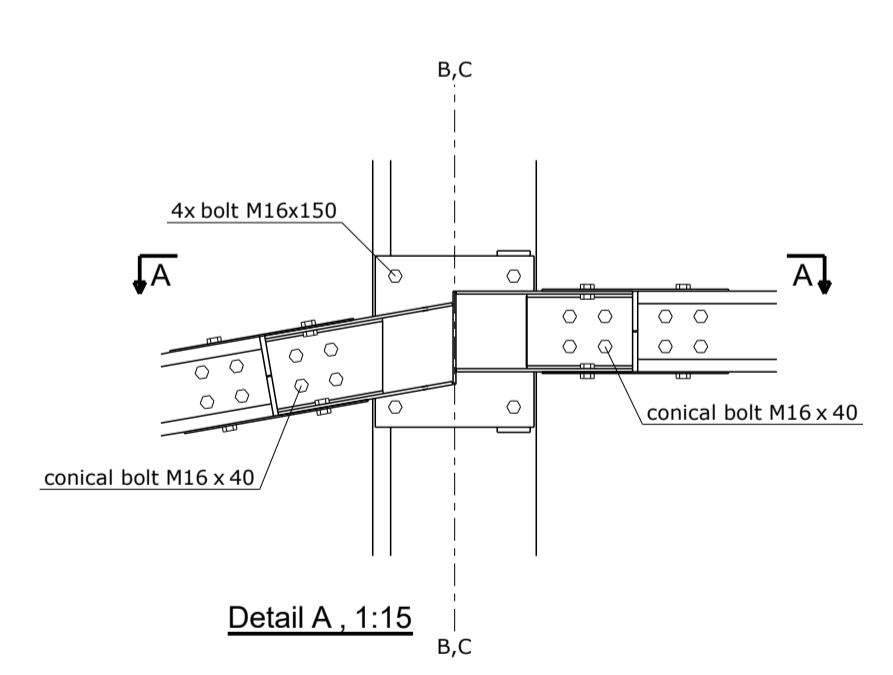

FRISO MAT <small>Innovators in steel buildings</small>	client: Champagne Bernard Bijotat <address of site>	FRISOHALL_FC_TR_10° width: 50.00 m height: 7.80 m length: 156.00 m
	Fmsomat Nord 17, Rue Paul Langevin F-93270 SEVRAN tel: +33 1 48 67 53 53 fax: +33 1 48 65 24 48 e-mail: infoparis@frisomat.fr	NVA & PPE scale: 1:15, 1:100 date: 20.12.2022