

Algemene opmerking:
Bouwtoleranties / Stelruimte wordt in het werk
beoordeeld en mogelijk gecorrigeerd.
Alleen controle Hout!
Staal en Beton Derden!

Bloembak 50mm vrij houden van Beton
i.v.m. ventilatie. Ruimte wordt in het werk
afgewerkt middels Azobe lat aan bovenzijde

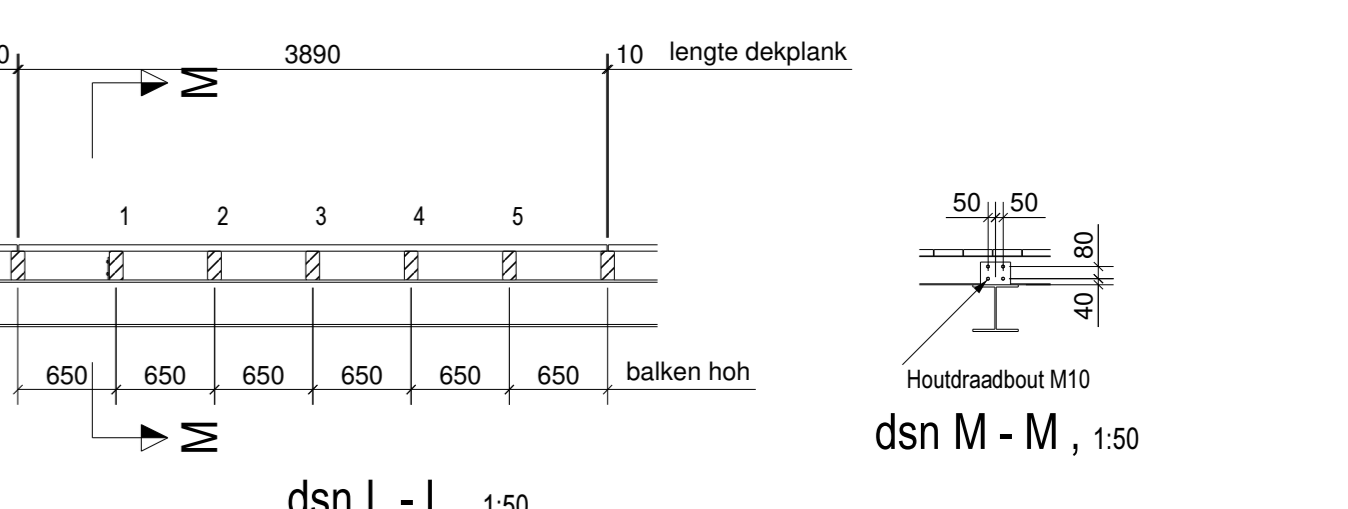
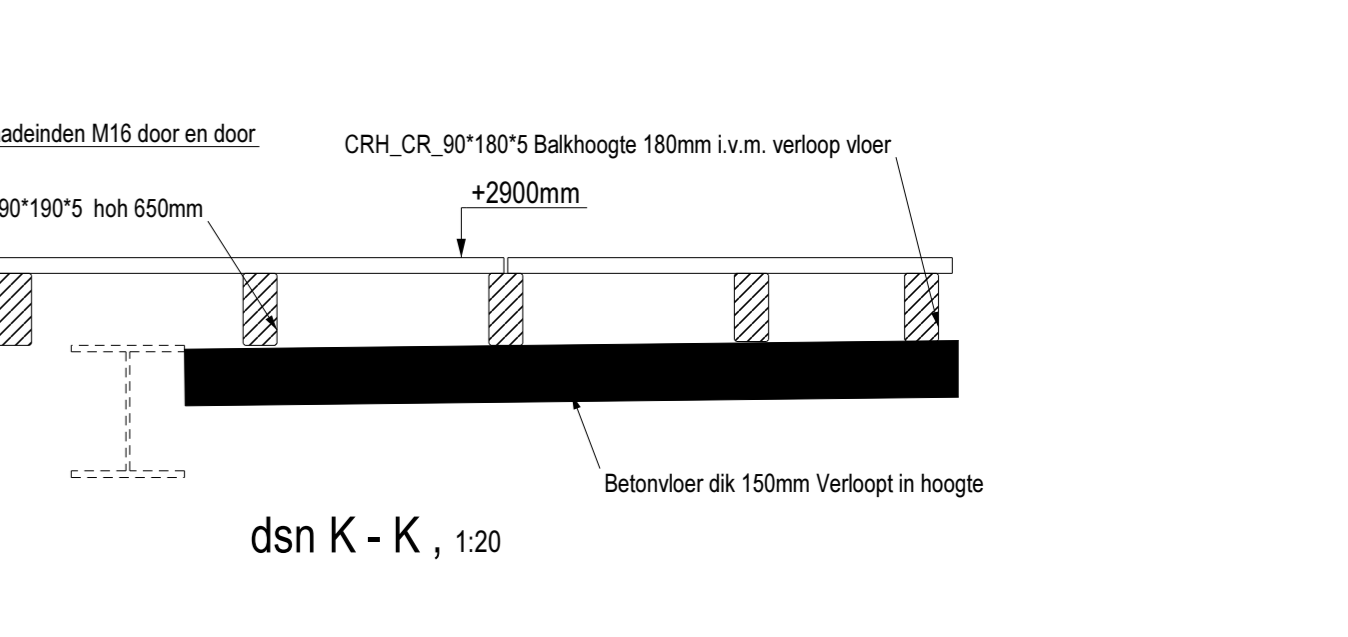
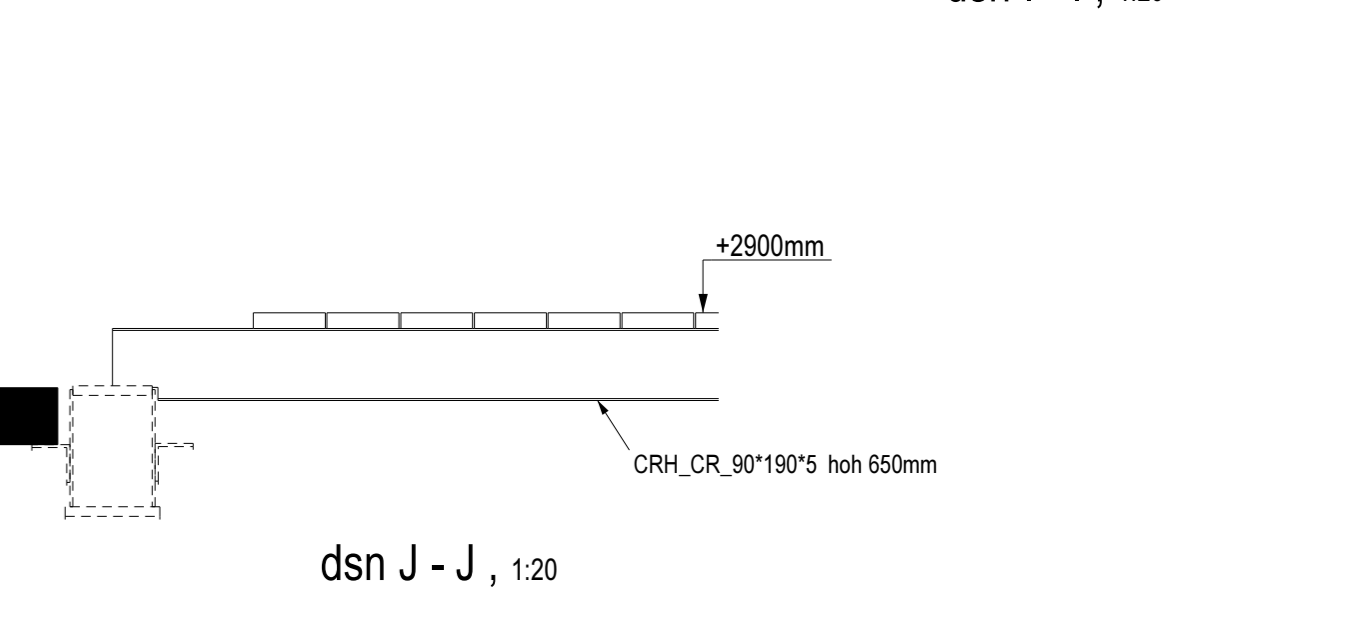
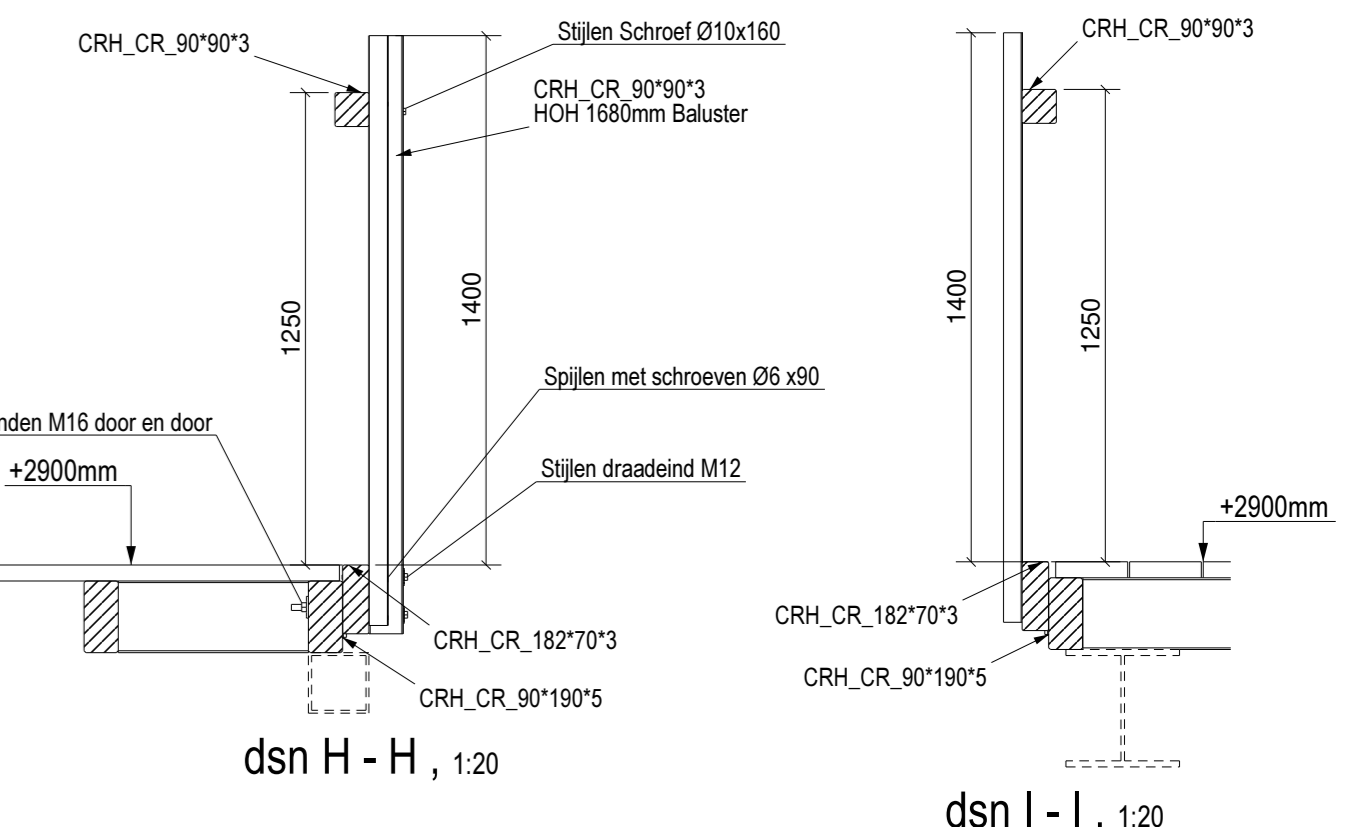
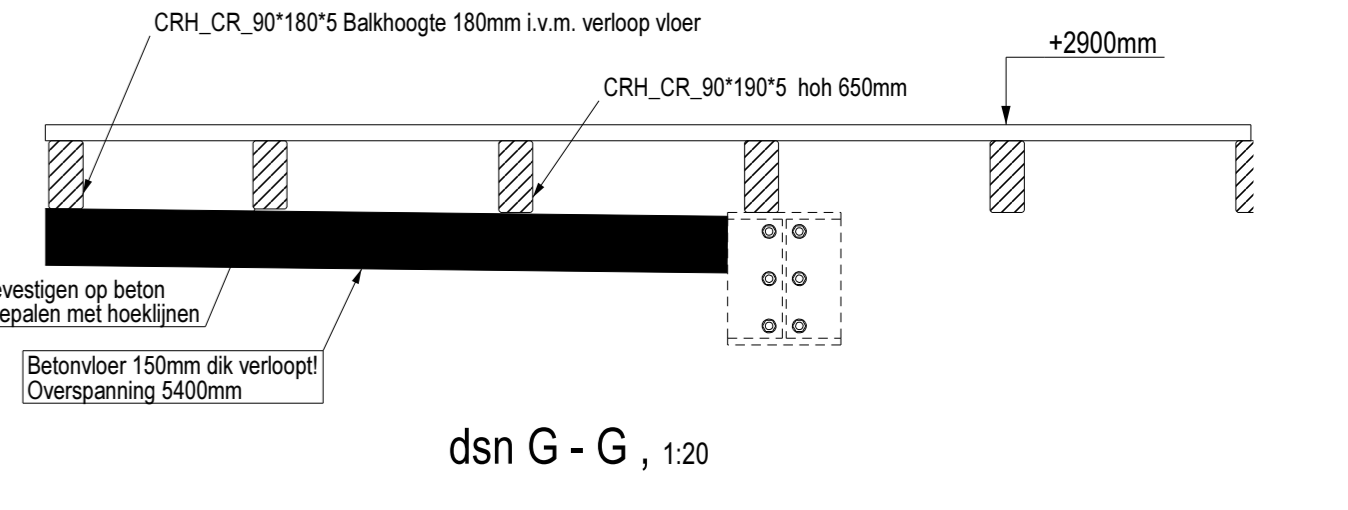

Algemeen Bevestiging leuning:
Onderste balk dmv draadenden M16
Stijlen onderzijde met draaïend M12x180
Stijlen bovenzijde met schroef Ø10x160
Stijlen met schroeven Ø6x30

b	Wijz. Definitief	18.06.2021	p...
a	Wijz. ter Goedkeuring	31.05.2021	g...
Rev. no.	Revisie omschrijving	Revisie datum	Tek
BAM Wonen Bouwen Op Maat Postbus 25, 3430 AA, Nieuwegein Projectnummer: 20100297 - 150603 Lauerkwartier Utrecht 50 Appartementen, (WB50057) Overzicht Leefdek deel 1			
Groot Lemmer B.V. Innovatieweg 7 6447 SN, Heerenvoeren Nederland T +31(0)613-789-333 www.grootlemmerbng.com info@grootlemmer.com			Schaal Als aangegeven @ A0 Ontwerp - Gemaakt KR Gecontroleerd - Bas G [12] Type: -