

BAZ, 1:50

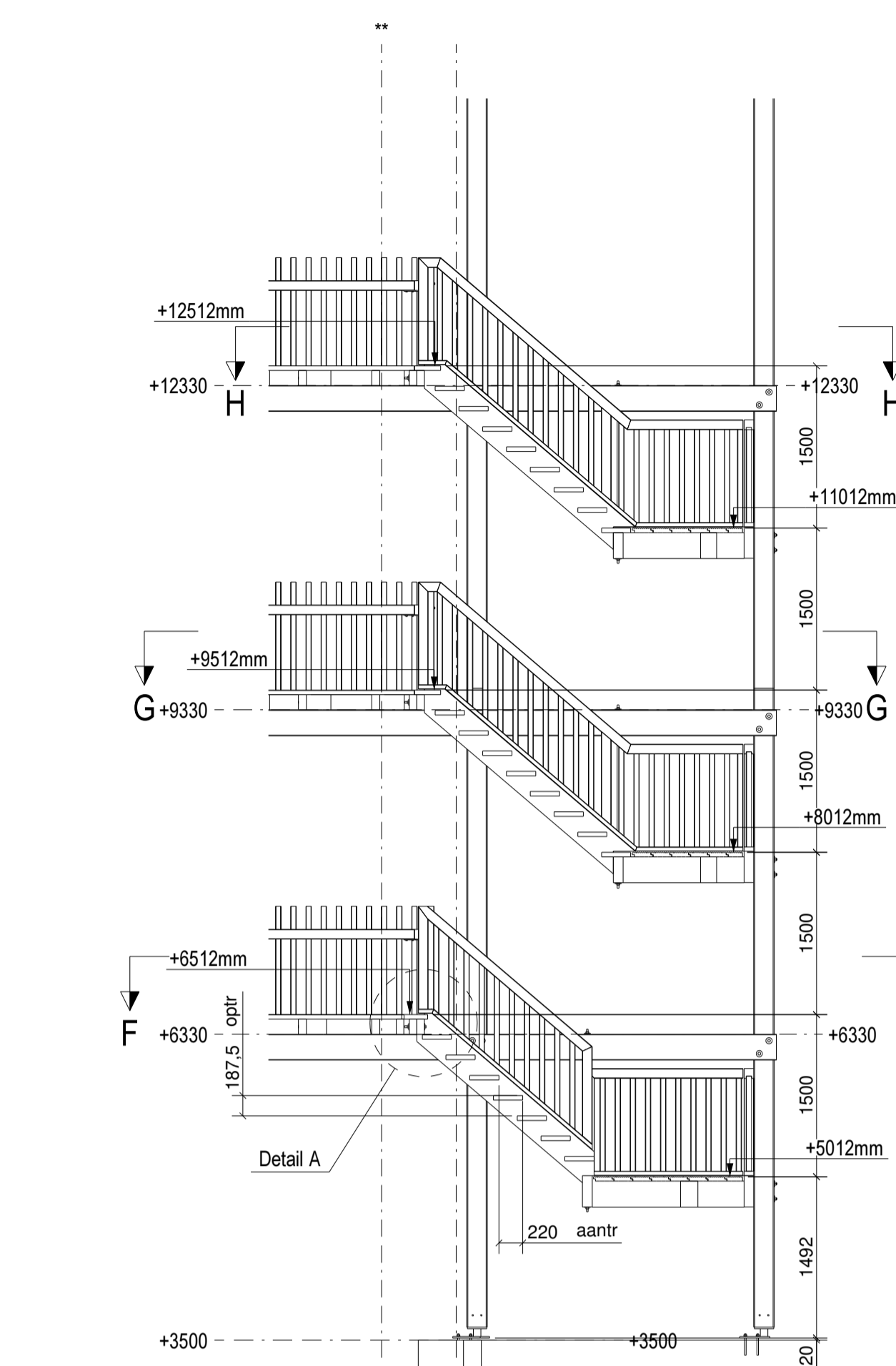

dsn A - A, 1:50

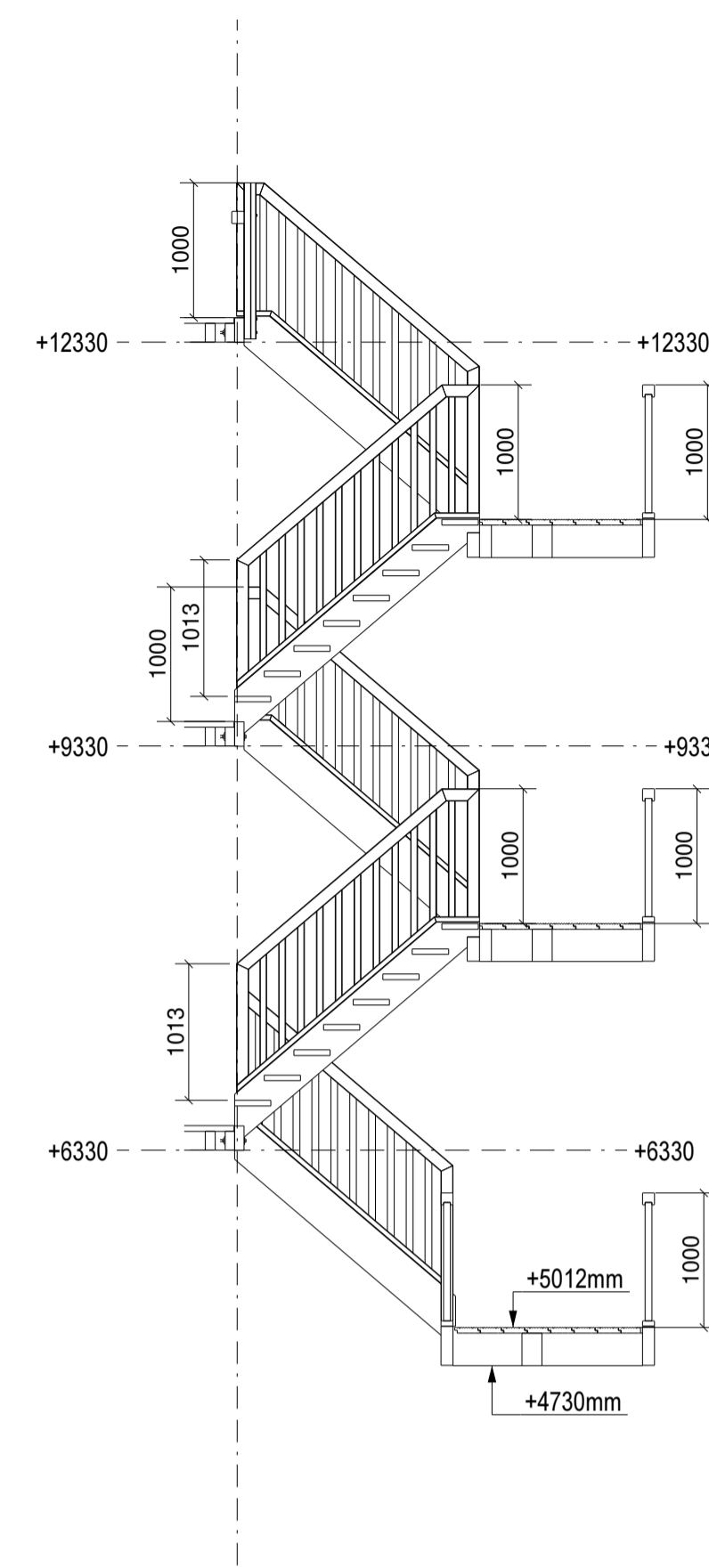

dsn B - B, 1:50

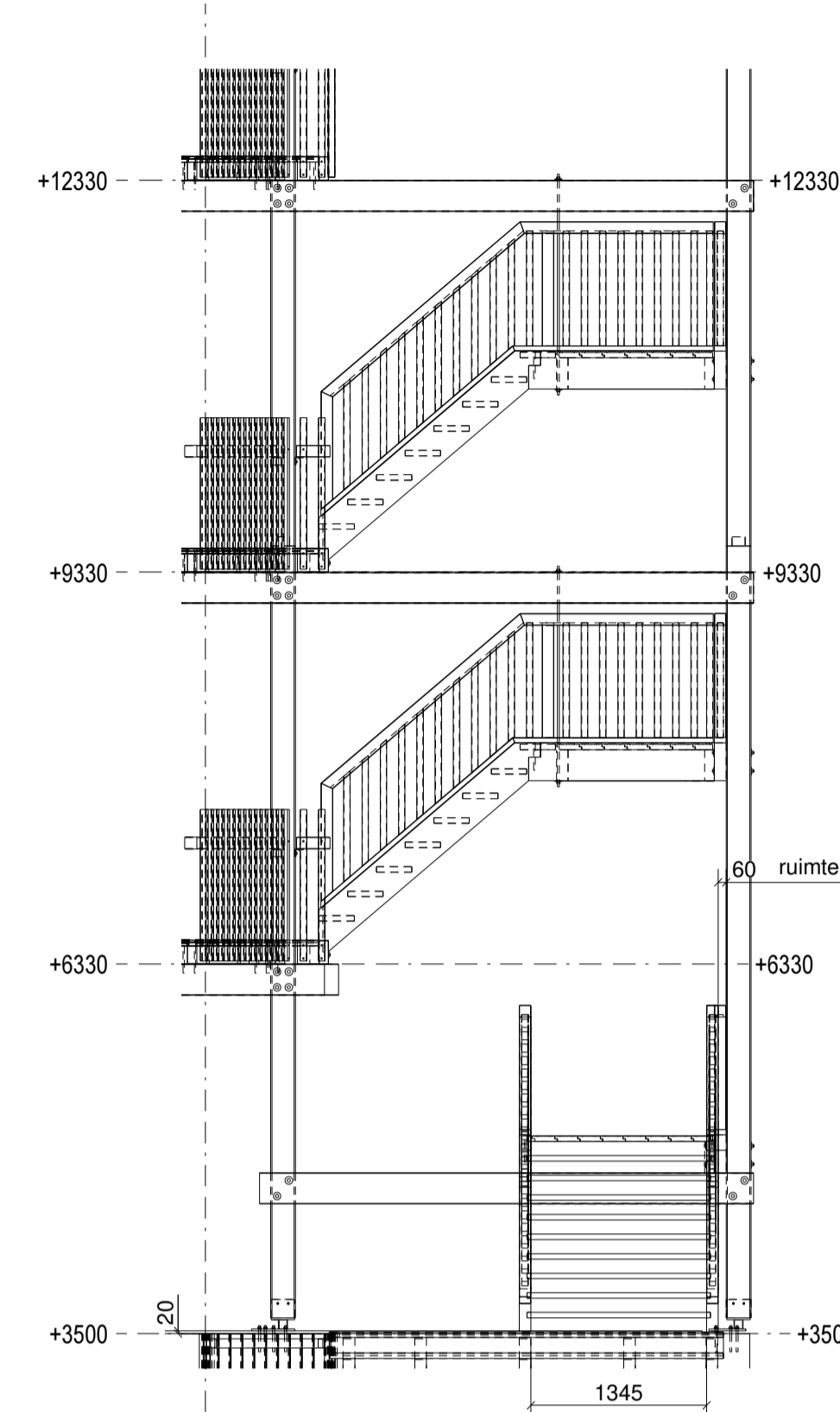

dsn C - C, 1:50

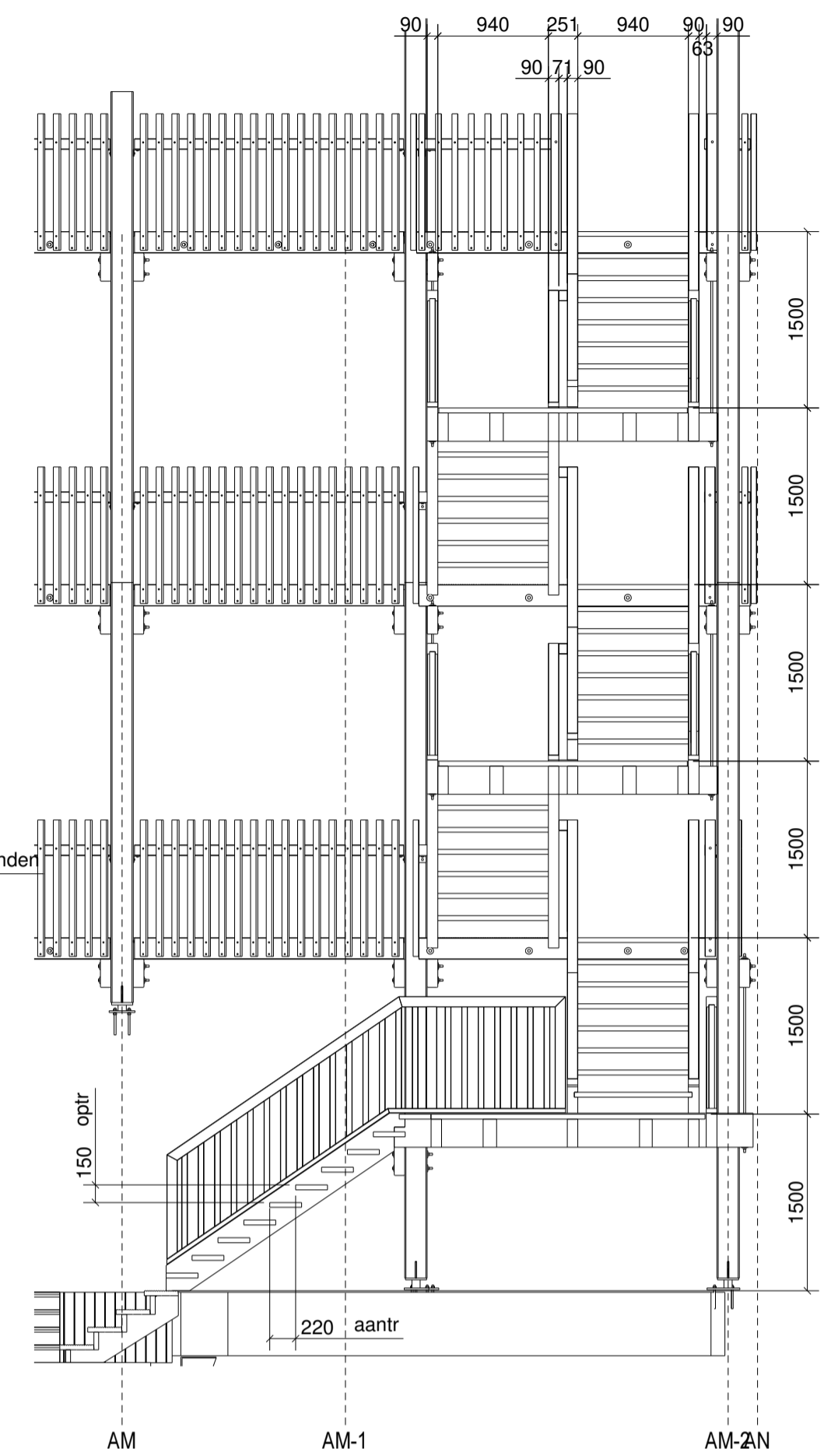

dsn D - D, 1:50

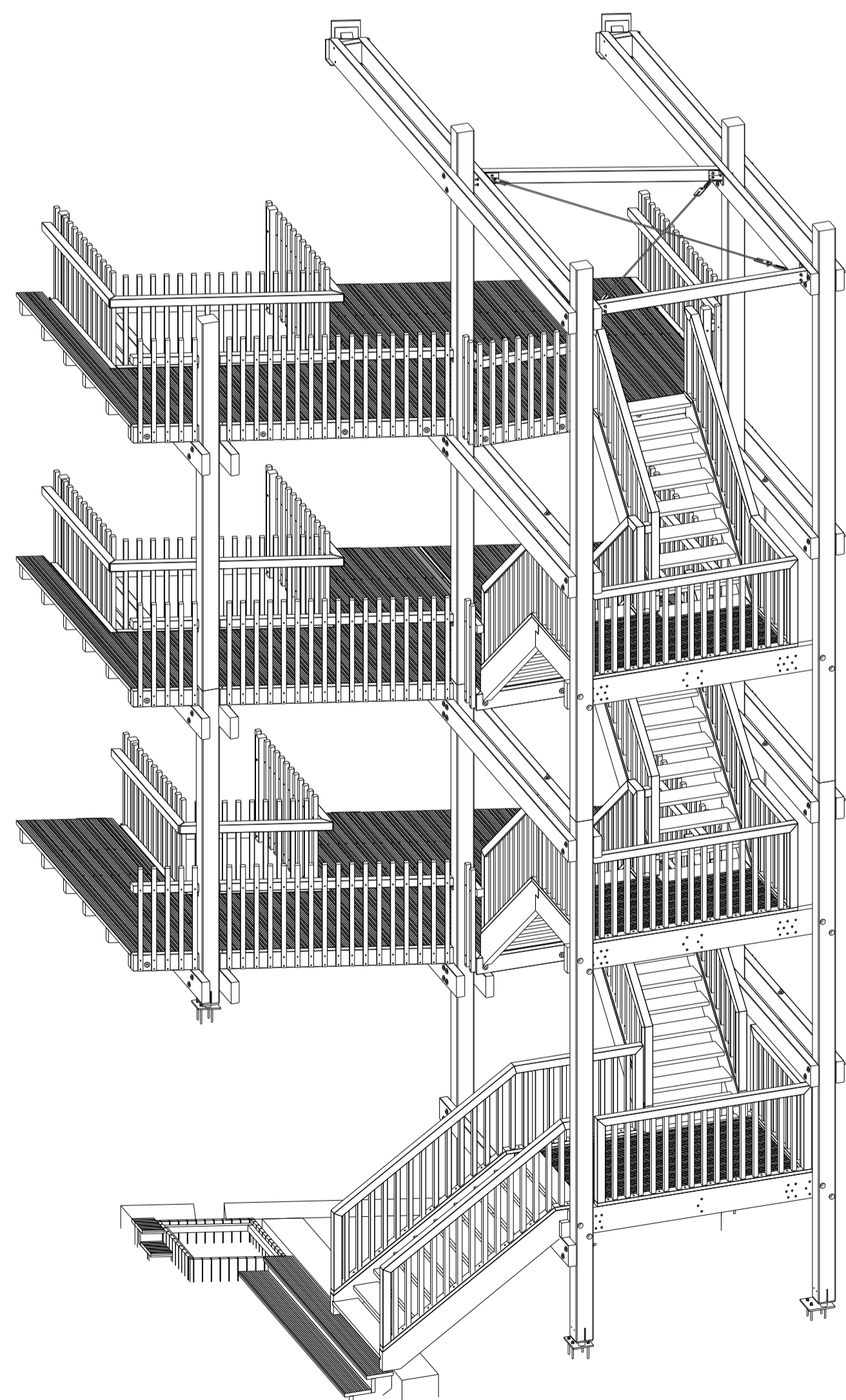

3D-Impressie, 1:50

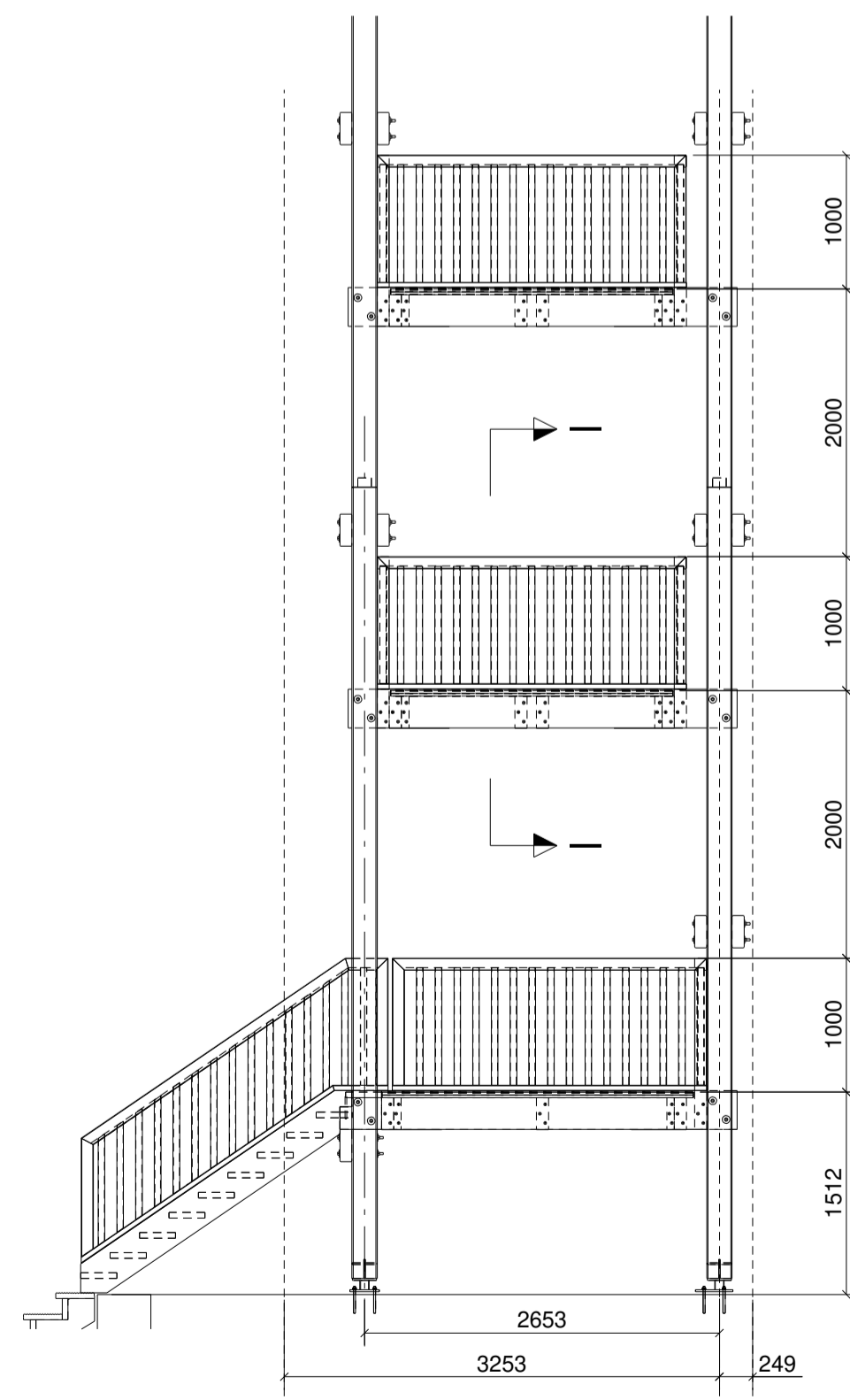

dsn E - E, 1:50

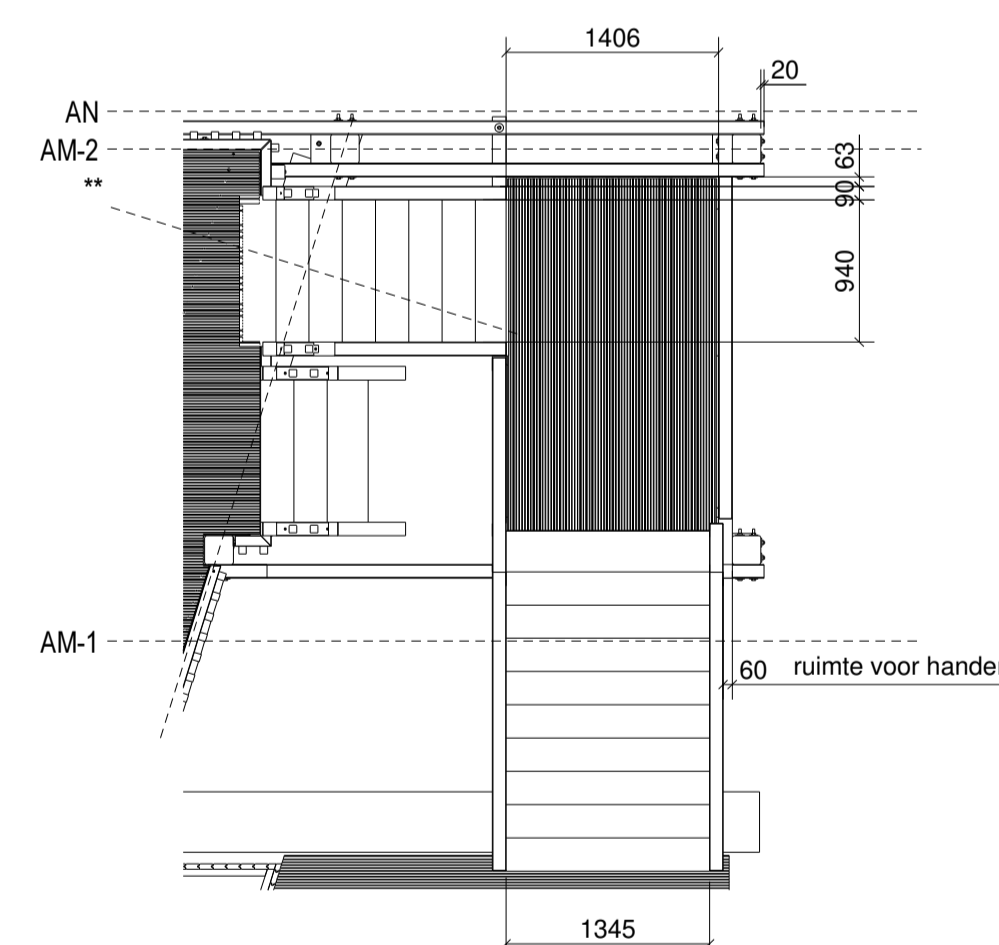

dsn F - F, 1:50

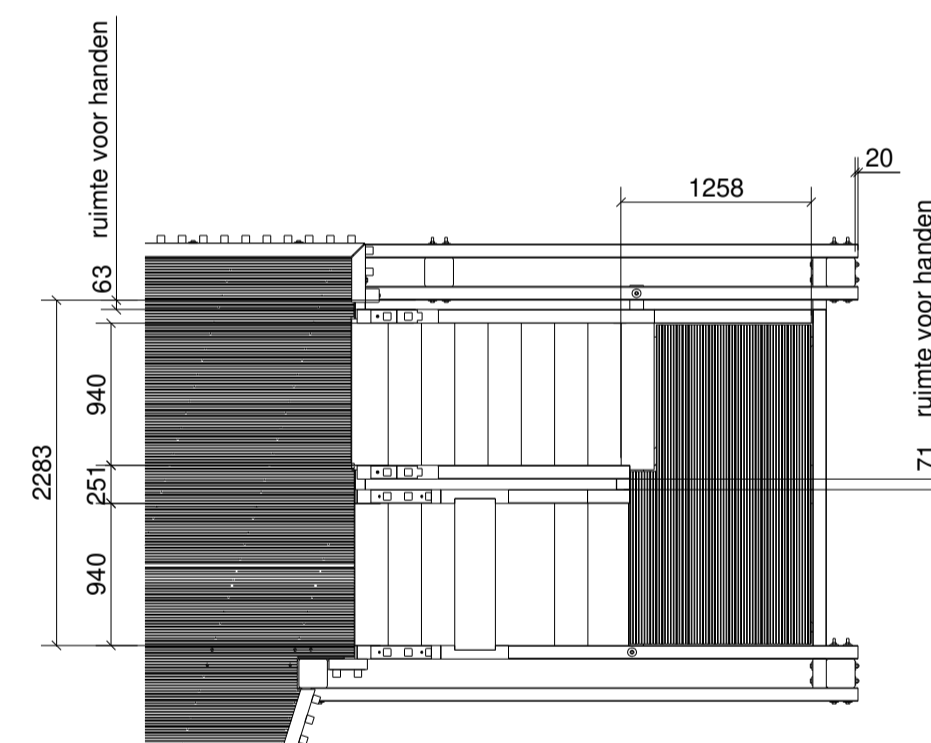

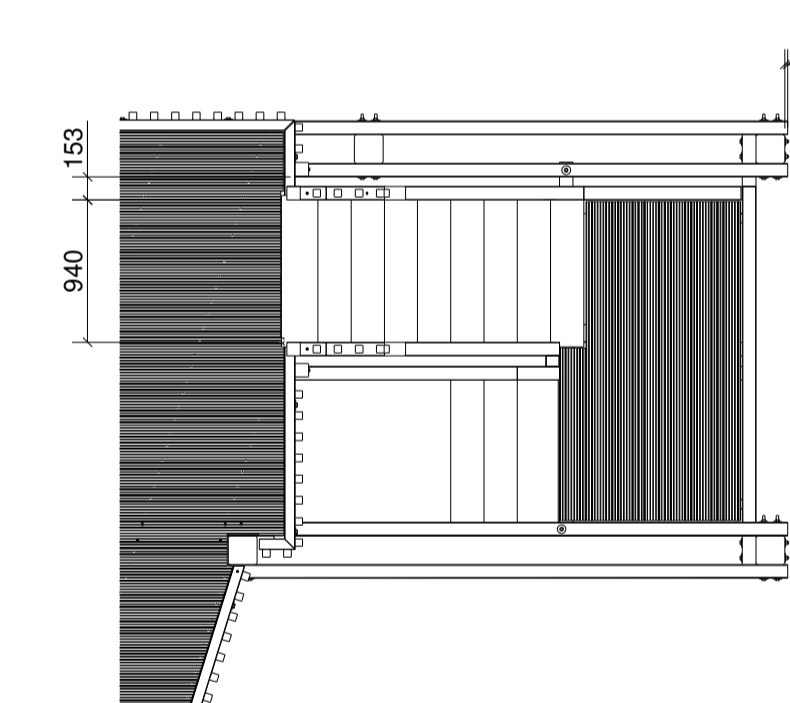

dsn G - G, 1:50

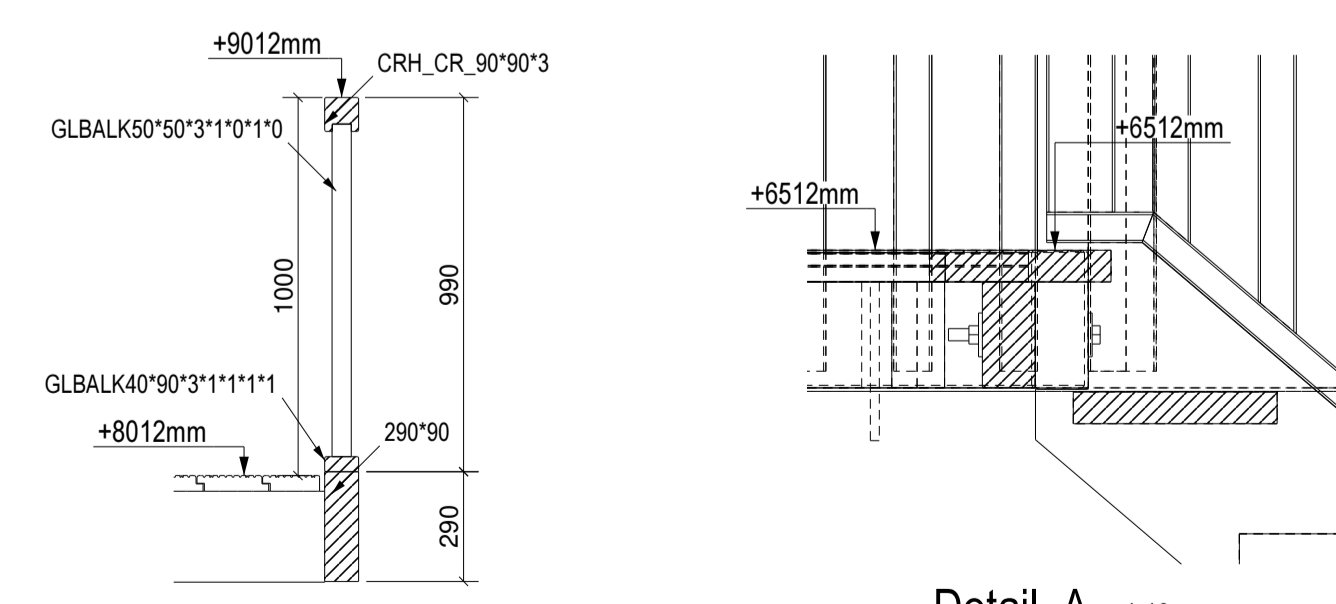

dsn H - H, 1:50



Detail A, 1:10

b	wijz opmerkingen TG	25.02.2021	P***
a	ter Goedkeuring	20.01.2021	P***
Rev. no.	Revisie omschrijving	Revisie datum	Tek
Opdrachtgever			
BAM Wonen Bouwen Op Maat			
Postbus 25, 3430 AA, Nieuwegein			
Projectomschrijving			
Laurierkwartier Utrecht			
50 Appartementen, (WB50057)			
Deel constructie			
Overzicht Trappenhuis			
Ontwerp			
-			
Getekend			
KR			
Gecontroleerd			
-			
Schaal			
Als aangegeven @ A1			
Project-ordernummer			
20190097-190693			
Blad			
G [6]			
PREFAZ00 Type: -			
 			
Groot Lemmer B.V. Innovatielaan 7 8447 SN Heerenveen Nederland T +31(0)513-789 333 www.grootlemmerbruggen.com info@grootlemmer.com			
 Alleen de producten die als zodanig zijn omschreven op dit document zijn FSC geïmponeerd, verantwoord boordbeheer.			
Dit document bevat informatie eigendom van GROOT LEMMER B.V. Iedere bekendmaking of gebruik van deze informatie of reproductie van dit document is uitdrukkelijk verboden zonder schriftelijke toestemming van GROOT LEMMER B.V.			