

Renovatie van de historische spoorkappen.  
Uitbreiding van de spoorkap 1/2.  
Nieuwbouw van de spoorkap 5/6.

Restauratie en uitbreiding  
van de bestaande gebouwen.

Het landschap van de stuwwal.  
De ondergrond van keermuren,  
tunnels en opgangen.  
De nieuwe entree als paviljoen  
verbonden met de ondergrond.

# OFFICE WINHOV

## snede DD

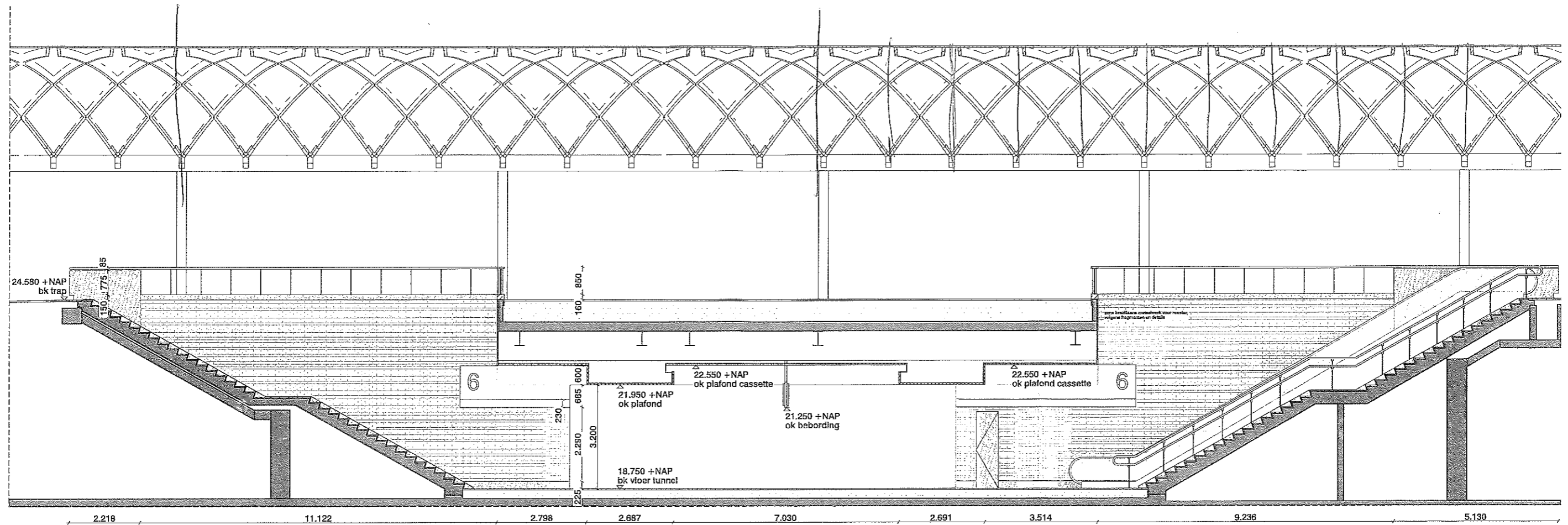

T.05  
optrede: 166,6 mm = 5830 mm / 35  
aanrede: 300 mm  
helling: 29,5°

T.06  
optrede: 166,6 mm = 5830 mm / 35  
aanrede: 300 mm  
helling: 29,5°

## snede EE

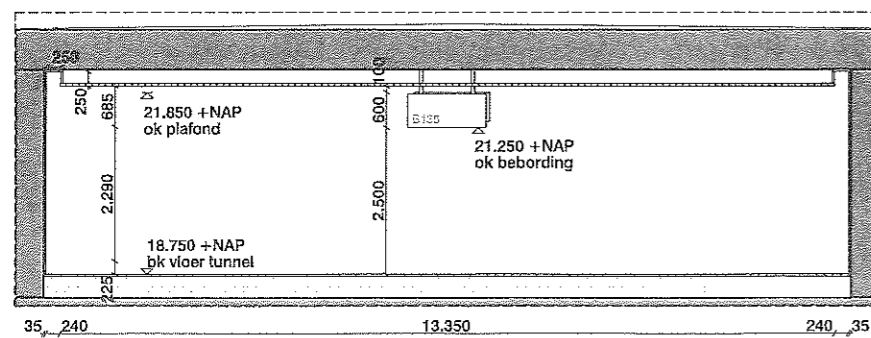

Doorsnede stijpunten perron 5-6 (boven) en doorsnede tunnel (onder).

# OFFICE WINHOV

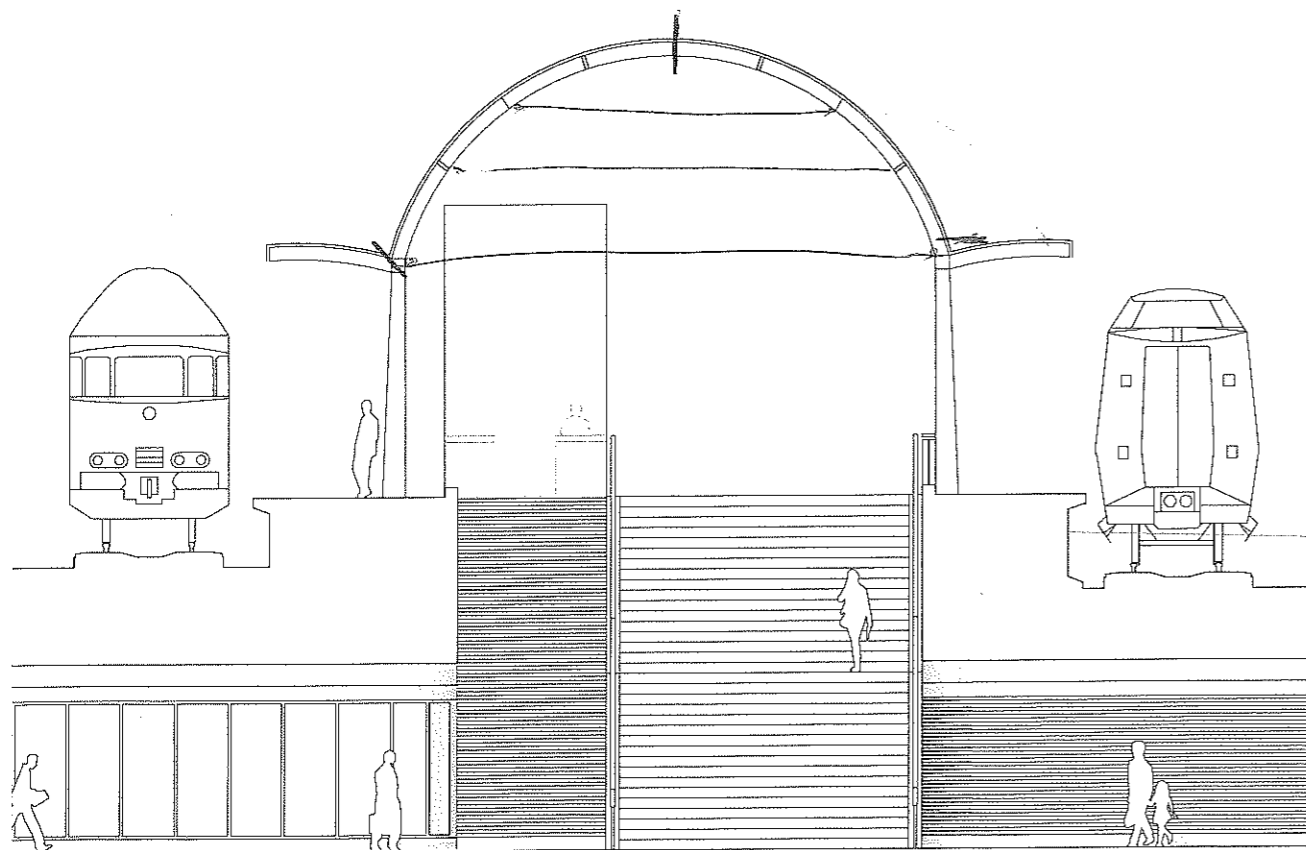
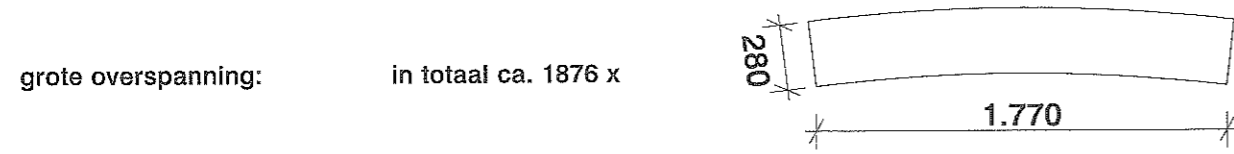

Principe doorsnede perronkap 5-6.

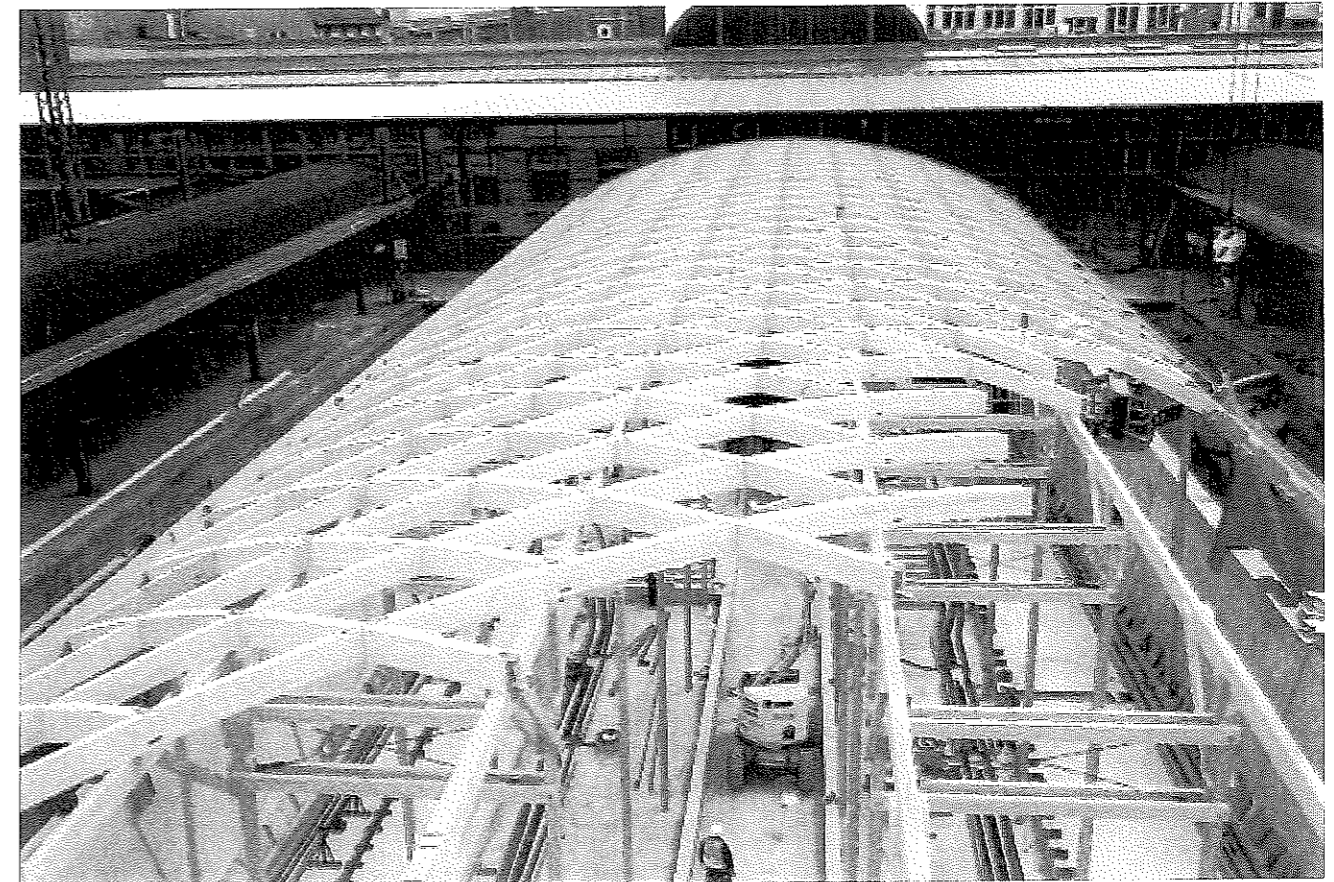

Kappen met het Zollinger principe, Cheticmap (F) en station Kassel (D).

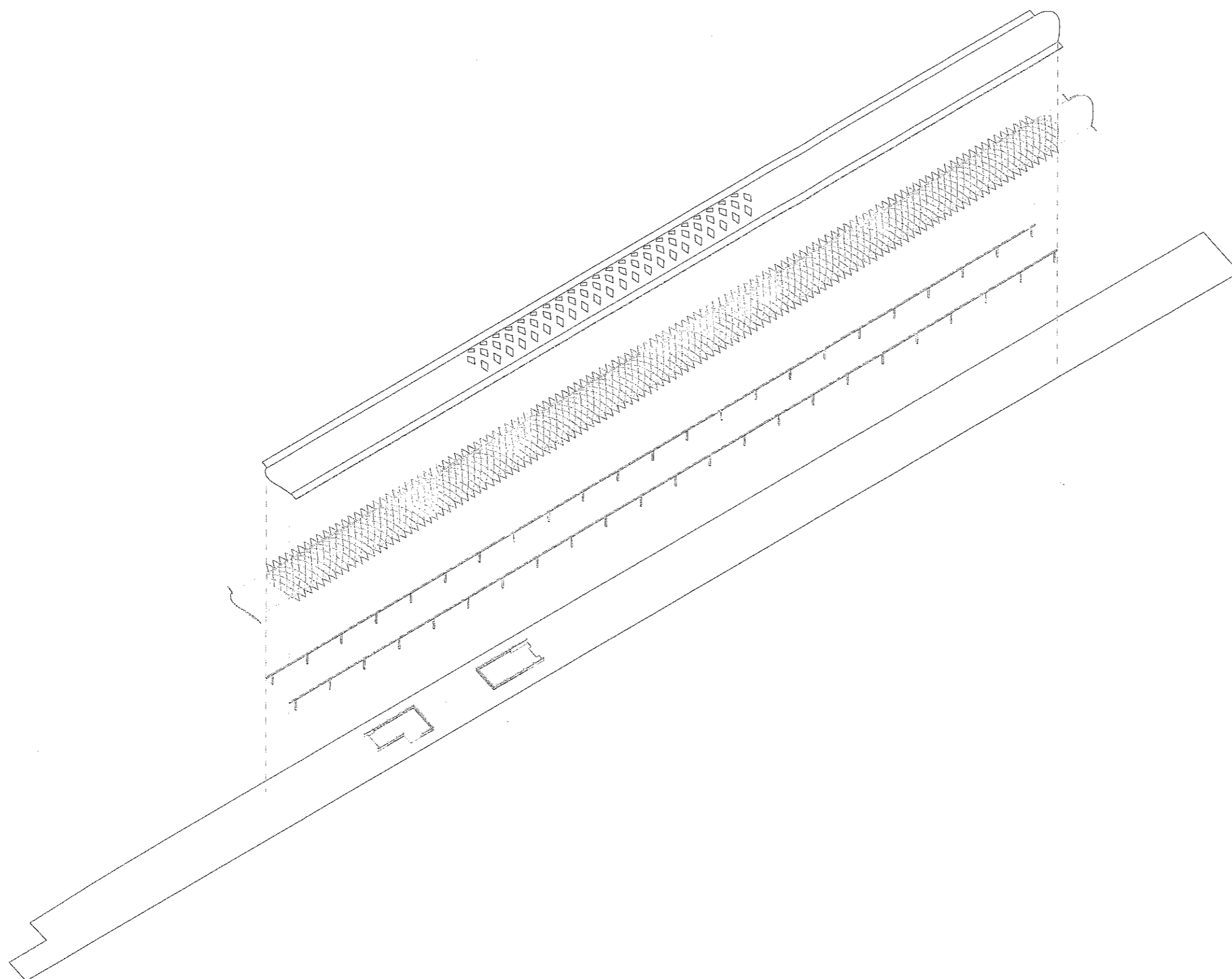

Daken met PV panelen.  
Daklichten ter hoogte van de opgangen.

Houten perronkap op stalen balken  
en kolommen.

Nieuw perron met opgangen.

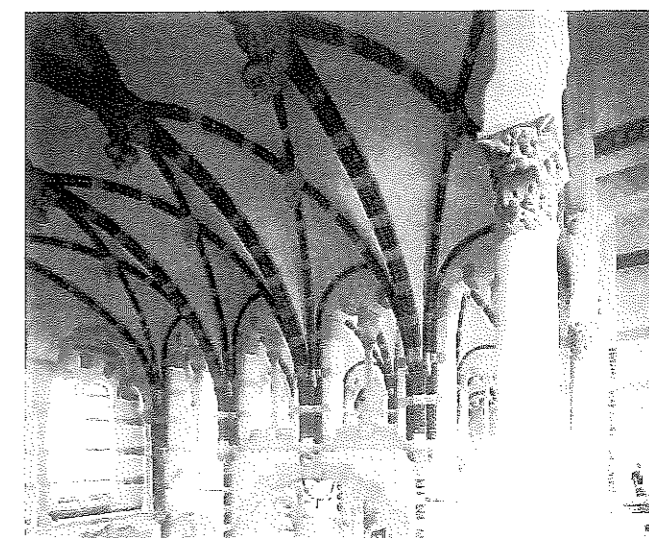

Neogotische gewelven in de stationshal  
van Peters.

