

WAPENINGSBORDEREL			
Nummer	#	Ø	Plooi vorm
(N63)	2	5-100/5-100	
(117)	2	Ø8	9830
(144)	2	Ø12	9830
(154)	4	Ø12	2140
(155)	2	Ø12	1585
(122)	10	Ø12	2315 550 L=2832
(150)	2	Ø12	2315 485 L=2767
(151)	3	Ø16	500 1400 L=2322
(166)	18	Ø8	50 600 L=1218
(FR1)	4	Ø16	750 150° 750 L=1499
Totaal:		239 kg (netten)	
Totaal:		97 kg (staven)	

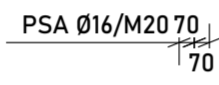

IB plaatselijk uit center zodat deze tussen stabox en staven Ø8 kan passeren

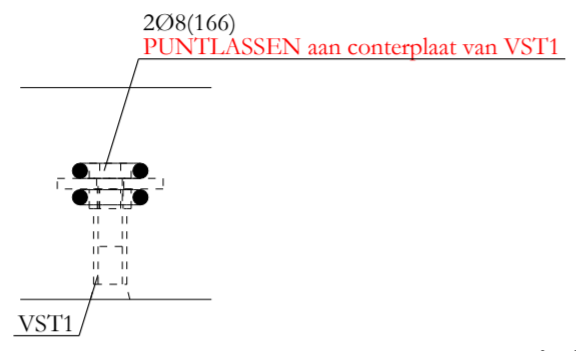
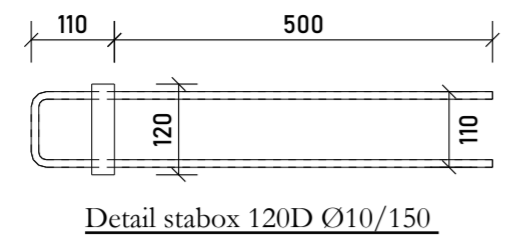
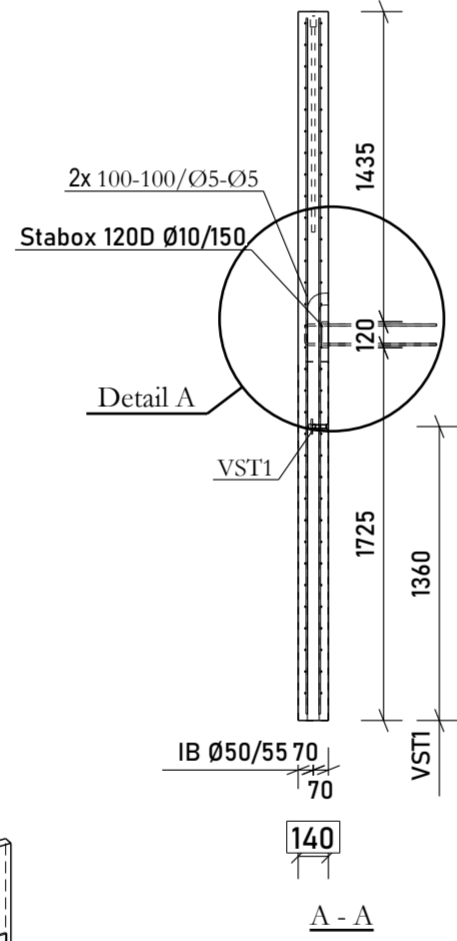
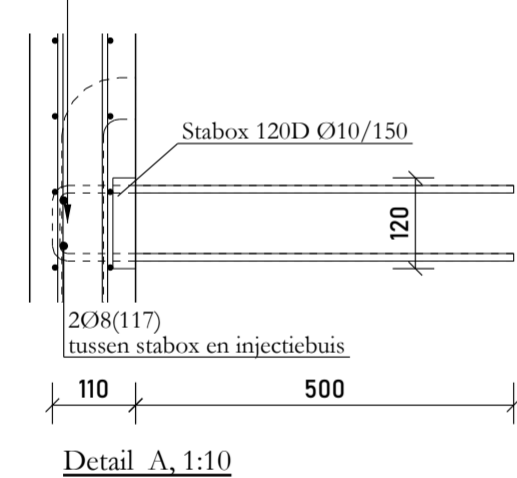

CENTER uitgang IB EXACT aanhouden!

1950

3280

A - A

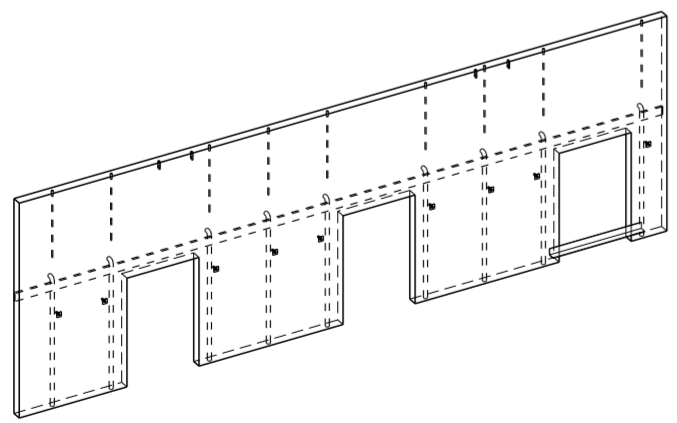
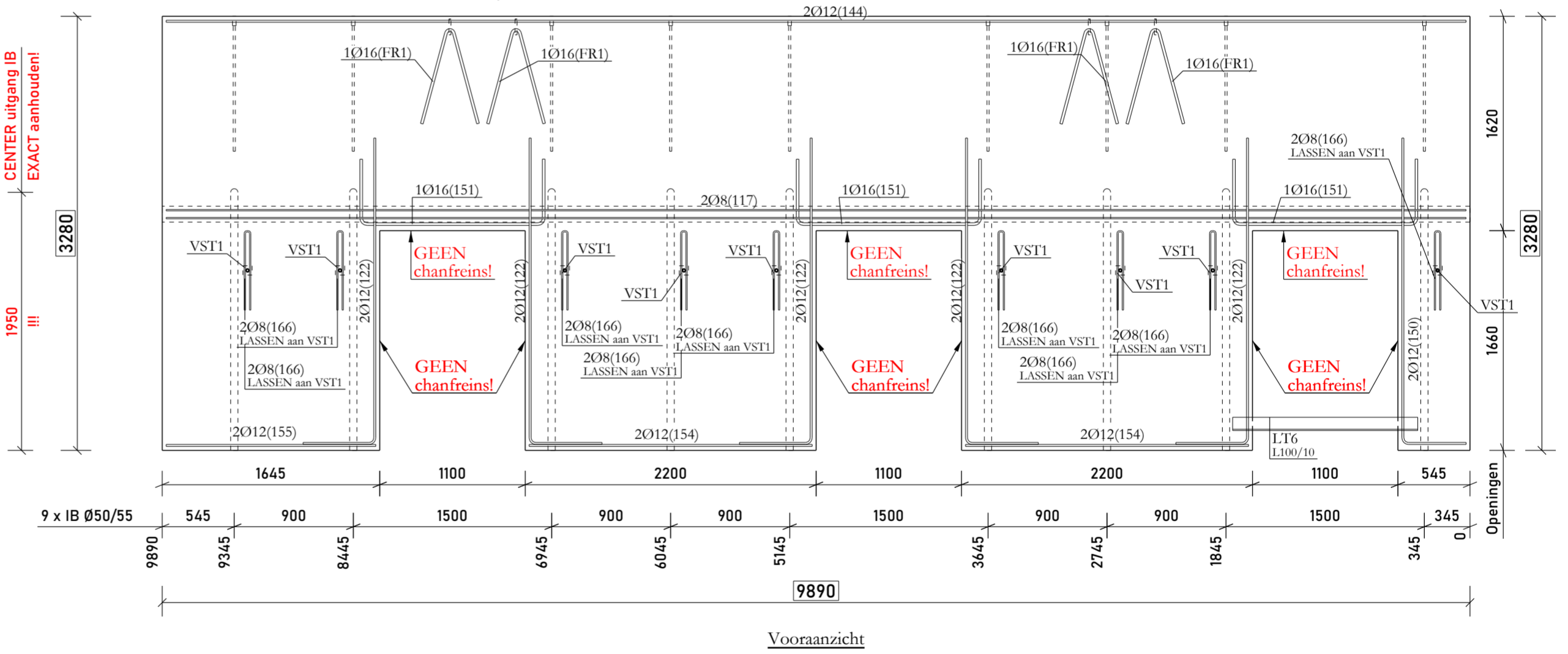
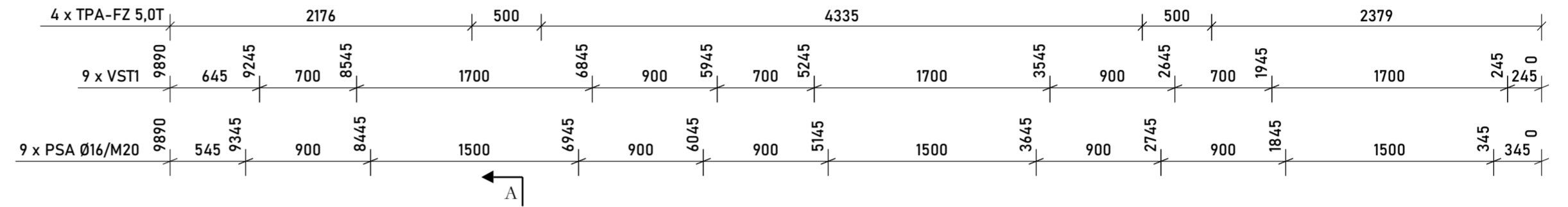
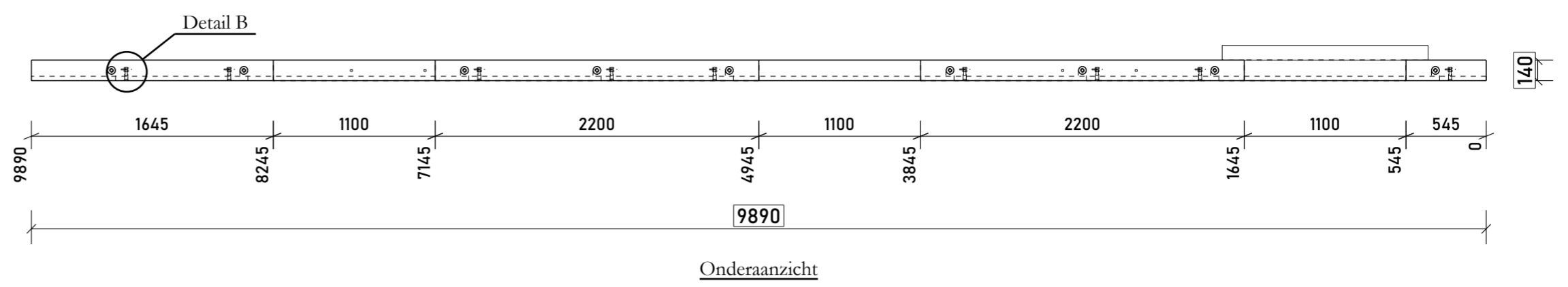

Uitgangen injectiebuizen allen dezelfde hoogte!

TOEBEHORENLIJST		
Bout M16 (45mm)	55 mm	9
PSA Ø16/M20	1020 mm	9
Stabox 120D Ø10/150	9890 mm	1
IB Ø50/55		9
TPA-FZ 5,0T		4
LT6		1
VST1		9

MATERIAAL EIGENSCHAPPEN	
Wapening	BE500TS/BE500ES
Sterkteklasse beton	C50/60
Omgevingsklasse	EE3
Betondekking	30 mm

SF24-0423-B0
KRDOS
8500 Kortrijk

STADSBADER

N.V. STADSBADER S.A.
Kanaalstraat 1, B-8530 Harelbeke
info@stadsbader.com - www.stadsbader.com

DATUM:	26/11/24	MERK:	14VG631
GETEKEND:	JD	AANTAL:	1
GEWICHT:	9.06 ton	DIKTE:	140 mm
OPPERVLAKTE:	32.44 m²	INDEX:	
VOLUME:	3.77 m³	DATUM:	